

LETTI

MORELATO

E B A N I S T E R I A I T A L I A N A

## Villa on the lake / *modern luxury style*

Modern design and refined style characterize this luxury villa on the lake, that stands out for its remarkable eclectic beauty and contemporary elegance. Here natural walnut hues combine with unexpected materials such as marble, stone, brass, leather and unique fabrics, harmonizing the furniture soft lines and shapes with the rigorous geometry of the architectural surroundings.

---

Design moderno e stile ricercato per questa lussuosa villa sul lago, che spicca per la sua particolare eclettica bellezza ed eleganza contemporanea. Alle tinte di legno noce naturale si combinano marmi e pietre, ottoni, pelli e tessuti raffinati, contrapponendo forme e linee morbide degli arredi alla geometria rigorosa dell'architettura.





Joyce bed / letto 2809/F  
Joyce bedside table / comodino Art 1303/F  
Moby Dick armchair / poltroncina 3820/F



Bedside table made of ash wood with glass or marble top and brass handles and tips.

Comodino in legno di frassino con piano in vetro o pietra , maniglie e puntali in ottone.





Chest of drawers made of ash wood with glass or marble top and brass handles and tips.

Comò in legno di frassino con piano in vetro o pietra, maniglie e puntali in ottone.



## Villa in nature / *minimal warm chic*

This villa surrounded by greenery has a simple and minimalist style, where natural and raw find a perfect match between sobriety and elegance through a skillful use of materials. A mix of marble, warm stones and shades of gray creates the ideal environment for a line of modern furniture that enhances the various experiences of a pleasant daily life.

---

Stile semplice e minimalista per questa villa immersa nel verde, dove naturale e neutrale trovano il perfetto punto d'incontro tra sobrietà ed eleganza attraverso un uso sapiente dei materiali. Un mix di marmi, pietre calde e tinte di grigio creano un ambiente ideale per i mobili che accompagnano le diverse esperienze di vita domestica.





The Bellagio Collection features strong and refined details, such as chamfers and taperings, adding simplicity and appeal. Their essential shapes, interpreted by contemporary timeless design, are enhanced by the highest quality craftsmanship of leather and wood.

La Collezione Bellagio, attraverso le sue bisellature e rastremature, esprime un carattere deciso e raffinato ma al contempo semplice e di grande appeal. Le linee essenziali declinate in un design contemporaneo e senza tempo, sono impreziosite dalla qualità delle lavorazioni artigianali del legno e della pelle.





Bellagio bookcase / libreria Art 6201/F  
Moby Dick armchair / poltroncina Art 3820/F  
Bellagio small table / tavolino Art 5626/F

Bellagio writing desk / scrittoio Art 5002/F  
Bellagio small armchair / poltroncina Art 3809/F





Writing desk made of ash wood with leather flapping top and one drawer.  
Chair made of ash wood with upholstered seat.

Scrivania in legno di frassino con piano a ribalta in pelle e cassetto porta oggetti.  
Sedia in legno di frassino con seduta imbottita.

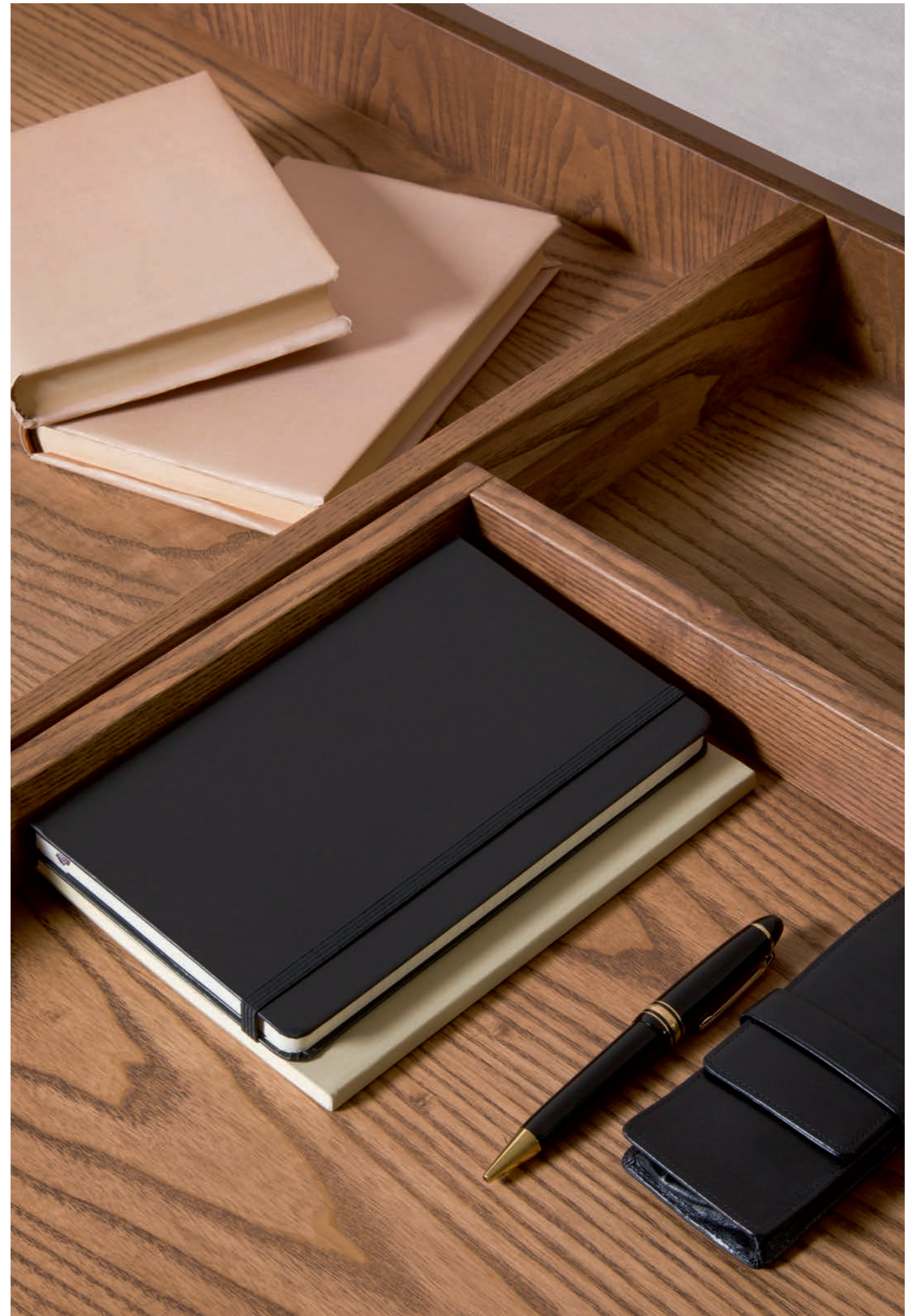



Bellagio bedside table / comodino Art 1301/F  
Bellagio bed / letto Art 2807/F

Bellagio chest of drawers / como' Art 1201/F  
Bellagio bench / panca Art 5334/F



Bed made of ash wood with upholstered headboard. Letto in legno di frassino con testiera imbottita.



## Urban appartement / *contemporary classic decò*

A color palette of green and pink connects the neutral stucco surfaces and the Venetian terrazzo floors creating a glamorous atmosphere. Unusual chromatic games embrace intense shades and soft nuances. In this apartment, the geometric and eclectic furniture lines blend into an unusual combination of architecture elements of 1920's, creating a strong aesthetic impact.

---

Una palette colori mix di verde e rosa connette superfici neutre in stucco e pavimenti in terrazzo veneziano, creando atmosfere glamour e giochi cromatici che abbracciano tonalità intense e nuance tenui. In questo appartamento i mobili dalle linee geometriche ed eclettiche si amalgamano con inediti accostamenti all'architettura degli anni venti creando un forte impatto estetico.

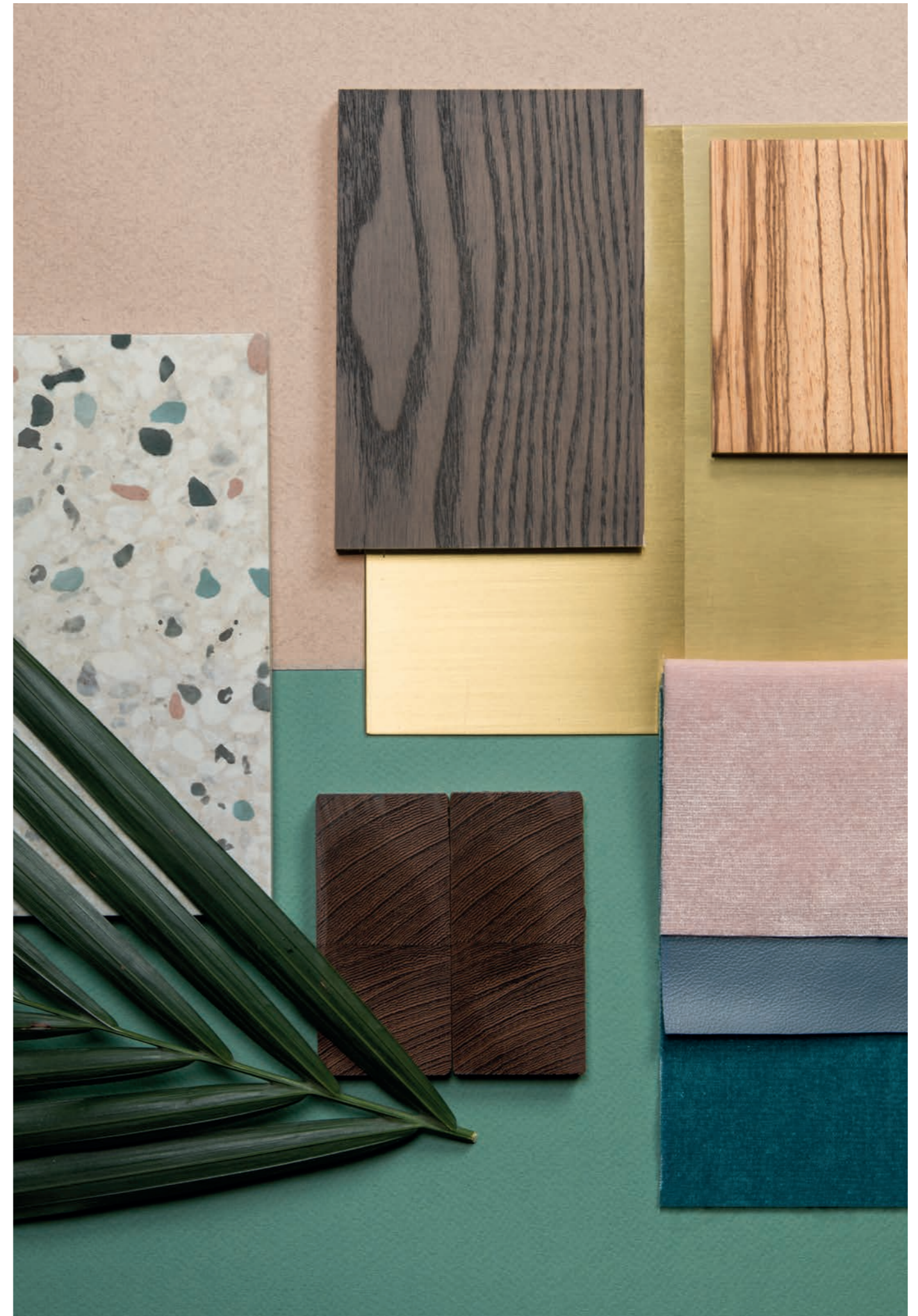



Jenny is a unique armchair entirely made of ash. Thanks to the elegantly curved back composed of a row of poles, the frame looks particularly light and airy. Perfect to give your home space a touch of design.

Jenny è un'originale poltroncina realizzata interamente in legno di frassino. Grazie all'elegante disposizione dei listelli sullo schienale curvato, la struttura risulta particolarmente leggera ed ariosa, perfetta per dare un tocco di design unico ad ogni ambiente della casa.





Swing bed / letto Art 2802  
Swing custom wardrobe system  
Moby Dick armchair / poltroncina 3820/F



Moby Dick is an armchair with an iconic and enveloping ash backrest evoking a whale tail. Thanks to its elegance and materiality, this graceful, sinuous and versatile armchair adapts to different environments: domestic or contract, expressing a perfect combination of woodcrafting and tailoring.

Poltrona Moby Dick ha un iconico e avvolgente schienale in frassino che ricorda la coda di una balena. Raffinata, sinuosa e versatile, si adatta ai diversi ambienti: domestici e contract, con eleganza e matericità esprimendo un perfetto connubio fra ebanisteria e sartorialità.



## Paris apartment / *elegant classic metropolitan*

This is a sophisticated environment with a neo-bourgeois flavor and a touch of “French charm”, embodying timeless taste and elegance. Dark hardwood essences and blue velvets, delicate colors and soft curtains are combined with the warm metallic shades of brass and bronze to create a luxurious, elegant and discreet atmosphere.

---

Un ambiente ricercato dal sapore neoborghese con un tocco di “french charme”, che esprime eleganza e raffinatezza senza tempo. Alle essenze di legno scuro sono associati velluti blu, tinteggiature e tendaggi delicati si accostano ai metalli dalle tonalità calde come ottoni e bronzi, per creare un’atmosfera lussuosa, elegante e discreta.







Pouf Capitonne Art 5335  
New York chest of drawers / como' Art 1271

Valentino bed / letto Art 2891  
New York bedside table / comodino Art 1361



Linear and thin structures characterize the Valentino beds. Stylish furniture with well-defined profiles, enhanced by comfortable padded headboards. The Valentino beds is available as a double bed and as a double bed with canopy.

Strutture lineari e sottili caratterizzano i letti Valentino. Arredi eleganti con profili ben definiti, impreziositi da comode testiere imbottite. I letti Valentino sono disponibili nella versione matrimoniale e nel modello con baldacchino.







## SWING DESK



*Essential and elegant writing desk with ash wood structure and top, with two drawers on the right and an open container on the left.*

Scrittoio essenziale ed elegante con struttura e piano in legno di frassino, completo di due cassetti a destra e di un contenitore a giorno a sinistra.

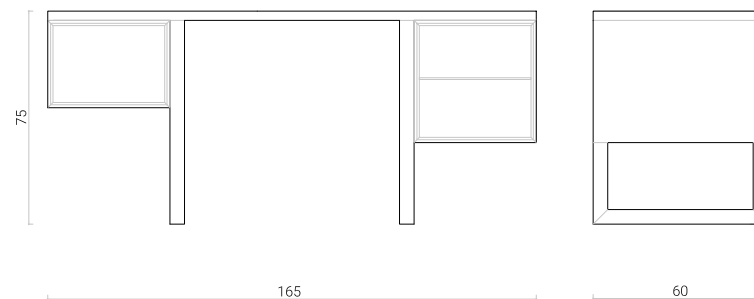



## SWING BED



*Single or double bed with upholstered sommier and custom headboard with the possibility to integrate with containers and padded head panels.*

Letti singoli o matrimoniali con sommier rivestito e testiera su misura con eventuali contenitori integrati e pannelli poggia testa imbottiti.

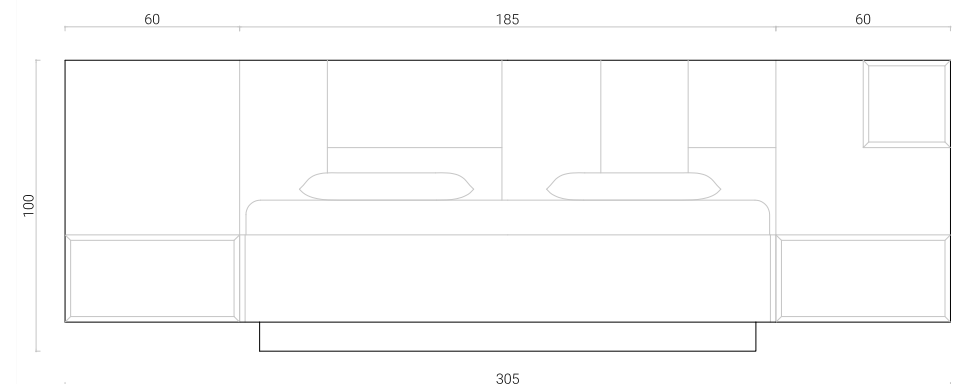

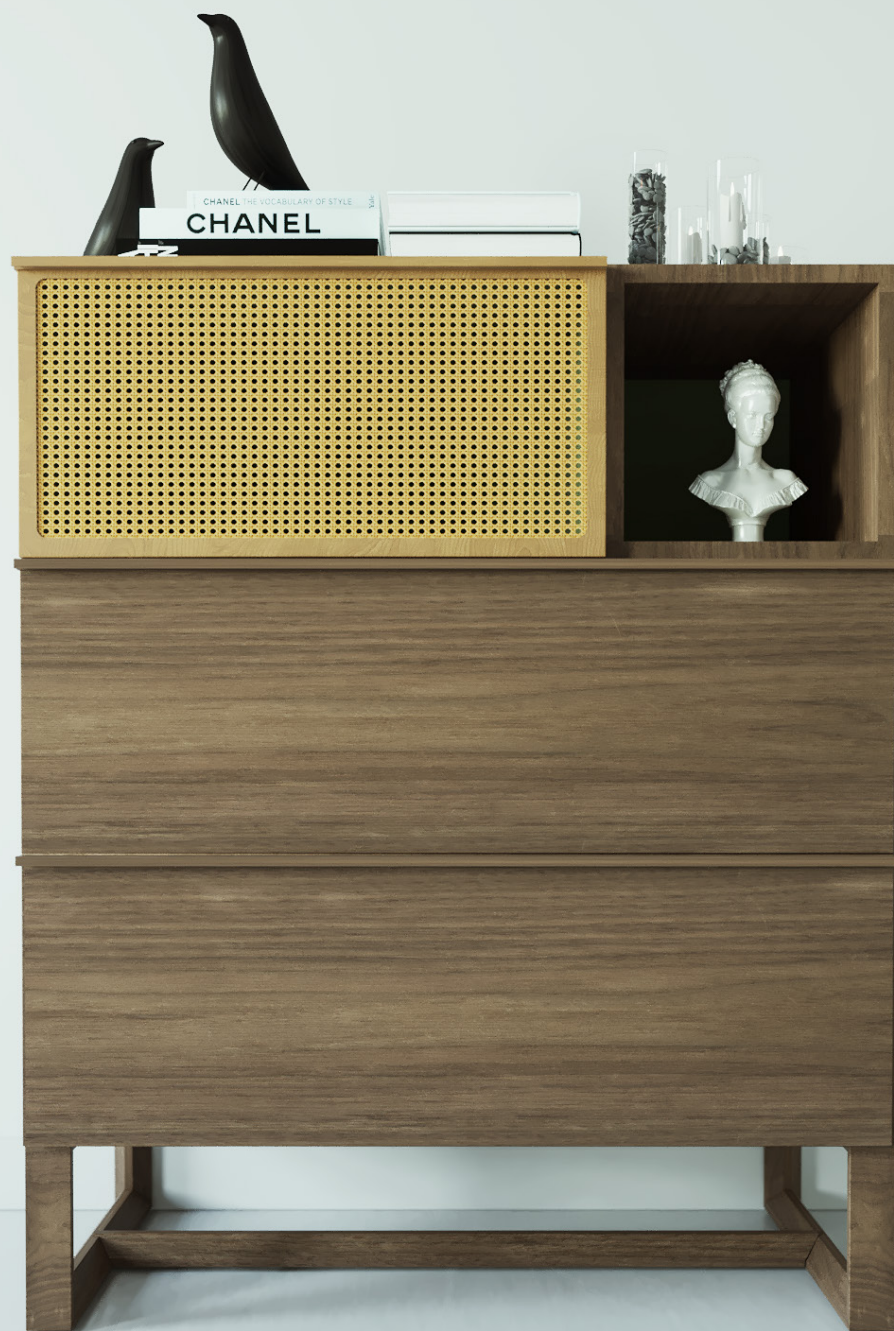

## SWING CHEST OF DRAWERS



*Modular cabinets or chest of drawers with doors or drawers that can be made of ash wood or other grains and materials.*

*Mobili contenitori e cassettiere componibili, con ante o cassetti realizzabili in essenze o altri materiali.*

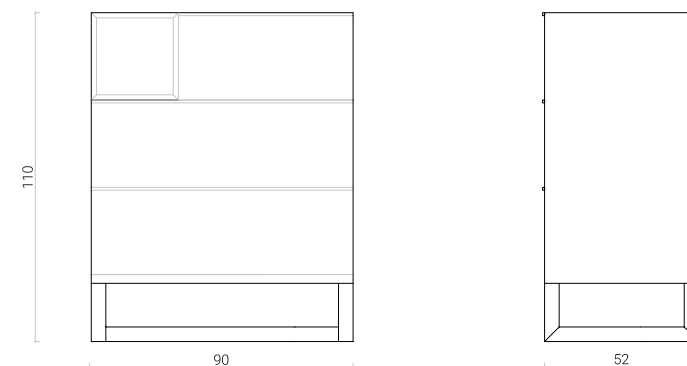









# BELLAGIO CHEST OF DRAWERS



*Dresser made of ash wood with three drawers.*

*Comò in legno di frassino con tre cassetti.*

*H 85 / L 130 / P 54*

*Design: Libero Rutilo*

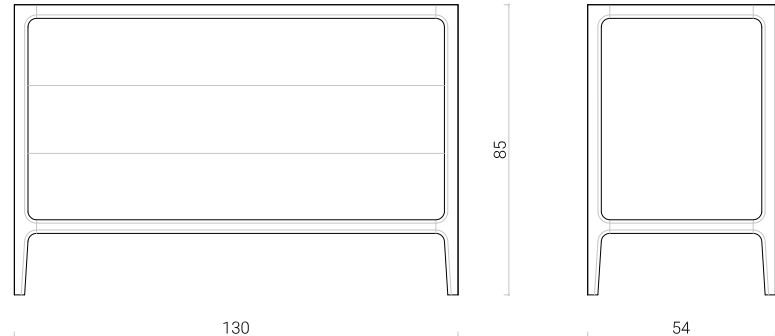

1201/F



# BELLAGIO BED



*Bed made of ash wood with upholstered headboard.*

*Letto in legno di frassino con testiera imbottita.*

**H 90 / L 213 / P 183 \***

*\* su misura a richiesta / custom size on demand*

*Design: Libero Rutilo*

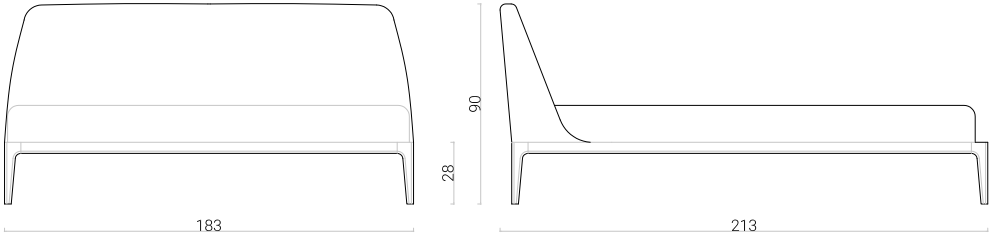

2807/F



## BELLAGIO BEDSIDE TABLE



*Bedside table made of ash wood with two glass shelves or one drawer.*

*Comodino in legno di frassino con due ripiani in vetroo con cassetto.*

H 55 / L 54 / P 39

*Design: Libero Rutilo*

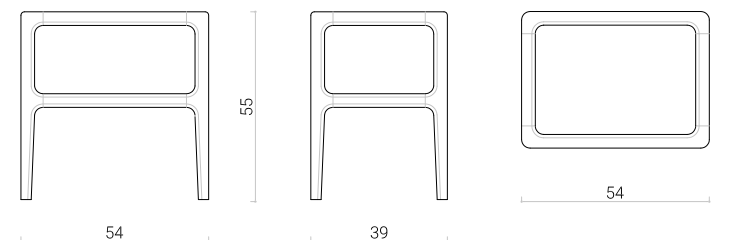

1301/F



La Collezione Bellagio, attraverso le sue bisellature e rastremature, esprime un carattere deciso e raffinato ma al contempo semplice e di grande appeal. Le linee essenziali declinate in un design contemporaneo e senza tempo, sono impreziosite dalla qualità delle lavorazioni artigianali del legno e della pelle.





Scrittoio in legno di frassino con piano a ribalta in pelle e cassetto porta oggetti.  
Sedia in legno di frassino con seduta imbottita.



# BELLAGIO WRITING DESK



*Writing desk made of ash wood with leather flapping top and one drawer. .*  
Scrittoio in legno di frassino con piano ribalta in pelle e cassetto porta oggetti.

H 88 / L 135 / P 66

*Design: Libero Rutilo*

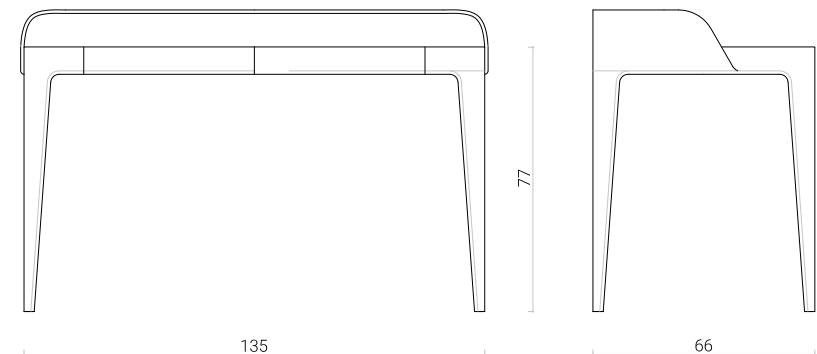

5002/F























Letto in legno di frassino con testiera imbottita.









Jenny è un'originale poltroncina realizzata interamente in legno di frassino. Grazie all'elegante disposizione dei listelli sullo schienale curvato, la struttura risulta particolarmente leggera ed ariosa, perfetta per dare un tocco di design unico ad ogni ambiente della casa.





## POLTRONCINA GENNY

DESIGN CENTRO RICERCHE

ART. 3805/F





Poltrona Moby Dick ha un iconico e avvolgente schienale in frassino che ricorda la coda di una balena. Raffinata, sinuosa e versatile, si adatta ai diversi ambienti: domestici e contract, con eleganza e matericità esprimendo un perfetto connubio fra ebanisteria e sartorialità.



# SEDIA METAMORFOSI

DESIGN PIETRO BARCACCIA

ART. 5199/F





# SGABELLO MYO

DESIGN GIULIO RENZI

ART. 5301/O



■ SGABELLO - LETTO MOENA

DESIGN CENTRO RICERCHE MAAM

ART. 5326





# SGABELLO ZERO

DESIGN FRANCO POLI

ART. 5325/N





■ DORMEUSE PAOLINA  
DESIGN CENTRO RICERCHE MAAM  
ART. 2242



■ LETTO MAGIC DREAM

DESIGN GIUSEPPE VIGANÒ

ART 2889/N



■ LETTO FELICE

DESIGN CENTRO RICERCHE MAAM

ART 2890



■ LETTO FORTUNATO

DESIGN CENTRO RICERCHE MAAM

ART 2806



Letto imbottito con struttura in legno di ciliegio. Imbottitura in pelle o tessuto su testiera e pediera. Supporto con doghe di legno.

MISURE: L 180 P 230 H 95

Upholstered bed made of cherry wood. Leather or fabric upholstery on headboard and footboard. Wooden slats mattress support.

MEASURES: L 180 W 230 H 95

■ LETTO GIÒ

DESIGN CENTRO RICERCHE MAAM

ART 2887 - 2884



■ LETTO VALENTINO

DESIGN CENTRO RICERCHE MAAM

ART 2891



■ LETTO UMBERTO

DESIGN CENTRO RICERCHE MAAM

ART 2885





MAAM





MAAM





MAAM











MAAM

### **Letto Felice**

Un letto elegante e leggero, così si presenta Felice.

La struttura, in legno di ciliegio con piedini in legno stonato a 'stiletto', è completata da due grandi cuscini imbottiti e removibili applicati alla testiera. Ben si abbina ai comodini Vittorio della collezione '900, anch'essi in legno di ciliegio, a due cassetti con particolari maniglie in pelle e ottone, qui presentati in finitura naturale.

*The Felice bed looks elegant and gracious.*

*Two padded removable cushions attached to the headboard complete its structure of cherry wood, with "stiletto" shaped feet. The bed forms a perfect set if combined with Vittorio bedside tables of the '900 collection also made of cherry wood which has two drawers with peculiar handles of brass and leather. Here presented in a natural finish*











### **Magic Dream**

Giuseppe Viganò crea per Morelato un letto unico, dove la testiera prende ispirazione dalle panche dei parchi e i comodini, in essa integrati, sembrano piccole sedute dove sostare.

Un letto, realizzato in legno massello di noce canaletto, che pare invitare alla lettura e nasconde nel nome un richiamo al totale relax.

*The unique bed that Giuseppe Viganò designed for Morelato has a headboard inspired by the benches and tables of a park, integrated in the headboard they seem small seats where to stop and rest.*

*The bed is made of solid walnut, which seems to invite you to read; its name refers to total relaxation.*















LETTI

BEDS



ART. 2807/F  
LETTO BELLAGIO

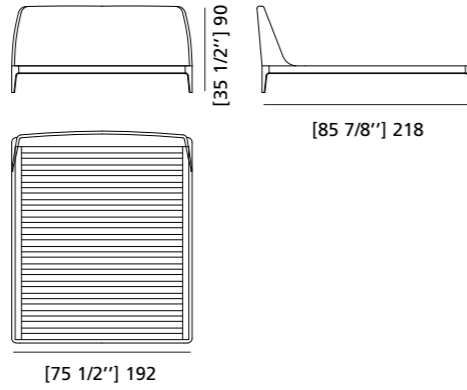

MISURE: L 192 P 218 H 90  
DESCRIZIONE: Letto in legno di frassino con testiera imbottita.  
Design: Libero Rutilo  
PESO: 100 kg - m<sup>3</sup>: 1,3  
COLLI: 4

MEASURES: L 192 P 218 H 90  
DESCRIPTION: Bed made of ash wood with upholstered headboard.  
Design: Libero Rutilo  
WEIGHT: 100 kg - m<sup>3</sup>: 1,3  
PIECES: 4

ART. 2808/F  
LETTO BELLAGIO

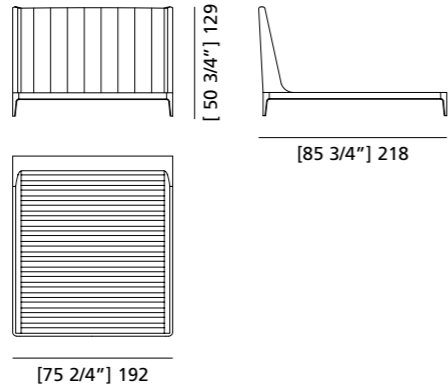

MISURE: L 192 P 218 H 129  
DESCRIZIONE: Letto con struttura in legno di frassino, testiera imbottita e rivestita in tessuto, piede a spillo. Supporto materasso con doghe in legno di faggio.  
Design: Libero Rutilo  
PESO: 110 kg - m<sup>3</sup>: 1,40 - COLLI: 4

MEASURES: L 192 P 218 H 129  
DESCRIPTION: Bed made ash wood with upholstered headboard.  
Design: Libero Rutilo  
WEIGHT: 110 kg - m<sup>3</sup>: 1,40 - PIECES: 4

ART. 2809/F  
LETTO JOYCE

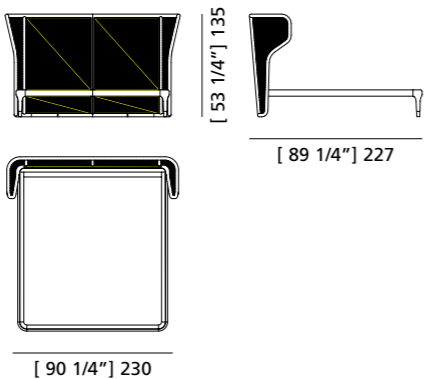

MISURE: L 230 P 227 H 135  
DESCRIZIONE: Letto con struttura in legno di frassino, testiera in parte imbottita e rivestita in tessuto, in parte in paglia di Vienna, piedi sagomati con bicchierino in ottone. Supporto materasso con doghe in legno di faggio.  
Design: Libero Rutilo  
PESO: 120 kg - m<sup>3</sup>: 2,20 - COLLI: 4

MEASURES: L 230 P 227 H 135  
DESCRIPTION: Bed made of solid ash wood with upholstered headboard and side Vienna straw lining.  
Design: Libero Rutilo  
WEIGHT: 120 kg - m<sup>3</sup>: 2.20 - PIECES: 4

ART. 2802/F  
LETTO SWING

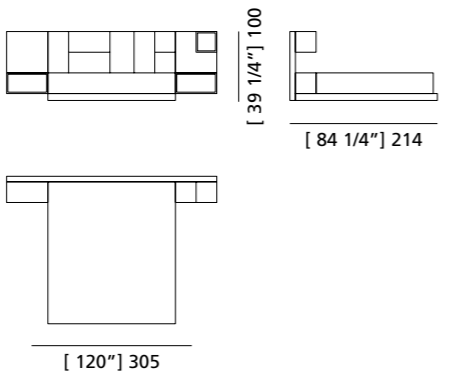

MISURE: L 305 P 214 H 100  
DESCRIZIONE: Letto con struttura in legno di frassino, testiera e giro letto rivestiti in tessuto, comodini e modulo a giorno applicati alla testiera. Supporto materasso con doghe in legno di faggio.  
Design: Libero Rutilo  
PESO: 150 kg - m<sup>3</sup>: 2,00 - COLLI: 5

MEASURES: L 305 P 214 H 100  
DESCRIPTION: Upholstered bed made of ash wood, with cushions on headboard. Lifiable slatted base.  
Design: Libero Rutilo  
WEIGHT: 150 kg - m<sup>3</sup>: 2,00 - PIECES: 5

ART. 2889/F  
LETTO MAGIC DREAM

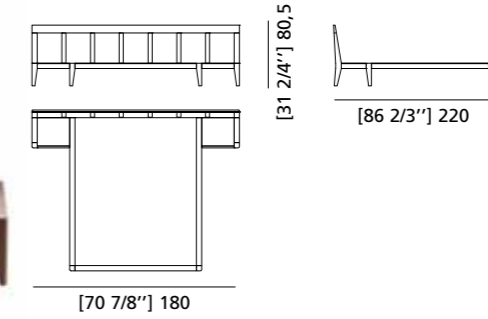

MISURE: L 180 P 220 H 80,5  
DESCRIZIONE: Letto con struttura in legno di frassino. 2 comodini con cassetto integrati nella testiera in legno massello. Supporto con doghe di legno. Su richiesta cuscini imbottiti applicabili alla testiera.  
Design: Giuseppe Viganò  
PESO: 100 kg - m<sup>3</sup>: 1,3 - COLLI: 3

MEASURES: L 180 W 220 H 80,5  
DESCRIPTION: Bed made of ash wood with two integrated bedside tables into the headboard. Wooden slats mattress support. Upon request removable padded cushions for the headboard.  
Design: Giuseppe Viganò  
WEIGHT: 100 kg - m<sup>3</sup>: 1,3 - PIECES: 3

ART. 2890  
LETTO FELICE

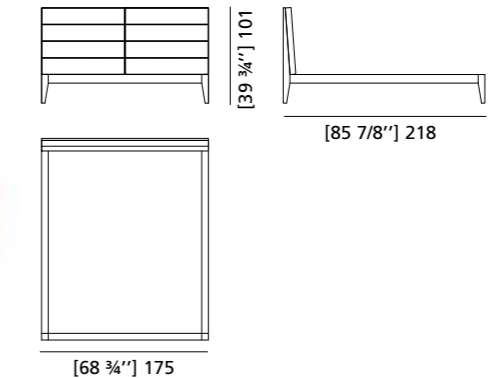

MISURE: L 175 P 218 H 101  
DESCRIZIONE: Letto con struttura in legno di ciliegio e piedini con bordo stondato. Testiera a doghe di legno con 2 cuscini removibili, imbottiti e sfoderabili in pelle o tessuto. Supporto con doghe di legno. Finitura: F32/C. Tessuto occorrente: cm 350x140  
Design: Centro Ricerche MAM  
PESO: 85 kg - m<sup>3</sup>: 1 - COLLI: 3

MEASURES: L 175 W 218 H 101  
DESCRIPTION: Bed made of cherry wood with headboard made of wooden poles with removable padded cushions. Wooden slats mattress support. Finishing: F32/C. Required fabric: cm 350x140  
Design by centro Ricerche MAM  
WEIGHT: 85 kg - m<sup>3</sup>: 1 - PIECES: 3

ART. 2887  
LETTO GIÒ

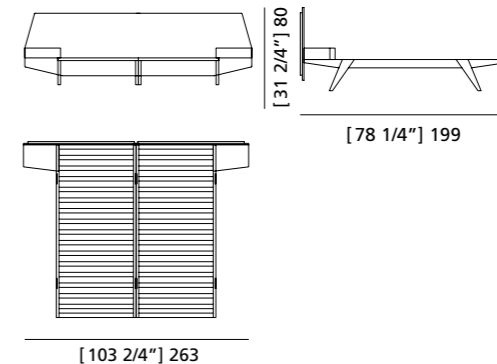

MISURE: L 263 P 199 H 80  
DESCRIZIONE: Letto con struttura in legno massello di ciliegio e supporto materasso in doghe. Testiera in legno con 2 comodini con cassetto integrati. Finitura: F32/C.  
Design: Centro Ricerche MAM  
PESO: 114 kg - m<sup>3</sup>: 2,5 - COLLI: 3

MEASURES: L 263 W 199 H 80  
DESCRIPTION: Bed with a solid cherry wood structure and headboard with integral bedside tables. Wooden slats mattress support. Finishing: F32/C.  
Design by centro Ricerche MAM  
WEIGHT: 114 kg - m<sup>3</sup>: 2,5 - PIECES: 3

ART. 2884  
LETTO GIÒ

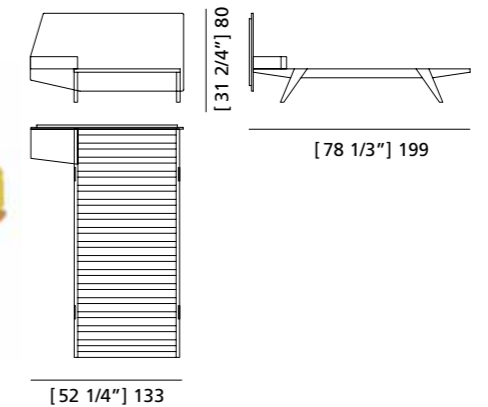

MISURE: L 133 P 199 H 80  
DESCRIZIONE: Letto con struttura in legno massello di ciliegio e supporto materasso in doghe. Testiera in legno con comodino integrato con cassetto. Finitura: F32/C.  
Design: Centro Ricerche MAM  
PESO: 55 kg - m<sup>3</sup>: 0,7 - COLLI: 2

MEASURES: L 133 W 199 H 80  
DESCRIPTION: Bed with a solid cherry wood structure and headboard with bedside table. Wooden slats mattress support. Finishing: F32/C.  
Design by centro Ricerche MAM  
WEIGHT: 55 kg - m<sup>3</sup>: 0,7 - PIECES: 2

ART. 2896/F  
SOMMIER GIO'

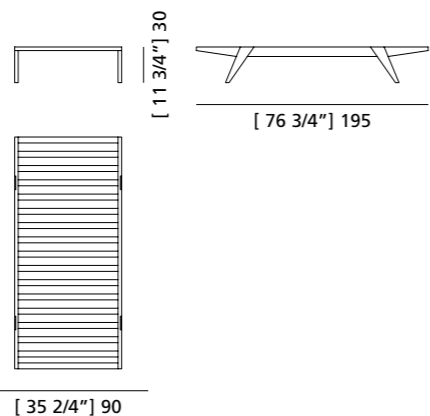

**MISURE:** L 90 P 195 H 30  
**DESCRIZIONE:** Letto sommier in legno di ciliegio.  
Design Centro Ricerche MAMM  
**PESO:** 40 kg - m<sup>3</sup>: 0,55 - **COLLI:** 1

**MEASURES:** L 90 P 195 H 30  
**DESCRIPTION:** *Sommier in cherry wood.*  
Design Centro Ricerche MAMM  
**WEIGHT:** 40 kg - m<sup>3</sup>: 0,55 - **PIECES:** 1

ART. 2806  
LETTO FORTUNATO

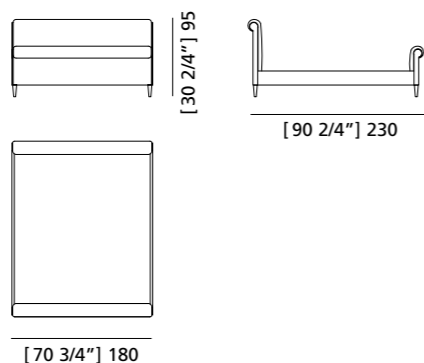

**MISURE:** L 180 P 230 H 95  
**DESCRIZIONE:** letto imbottito con struttura in legno di ciliegio. Imbottitura in pelle o tessuto su testiera e pediera. Supporto con doghe di legno.  
Tessuto occorrente: cm 410x140  
Design Centro Ricerche MAMM  
**PESO:** 80 kg - m<sup>3</sup>: 1 - **COLLI:** 4

**MEASURES:** L 180 W 230 H 95  
**DESCRIPTION:** *upholstered bed made of cherry wood. Leather or fabric upholstery on headboard and footboard. Wooden slats mattress support.*  
Required fabric: cm 410x140  
Design by centro Ricerche MAMM  
**WEIGHT:** 80 kg - m<sup>3</sup>: 1 - **PIECES:** 4

ART. 2801  
LETTO ORLANDO

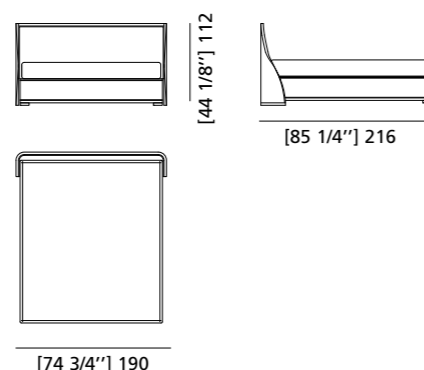

**MISURE:** L 190 P 216 H 112  
**DESCRIZIONE:** letto con vano contenitore in legno di ciliegio e pelle. Testiera con profilo in legno sagomato ad elica. Supporto materasso estraibile in doghe di legno. Tessuto occorrente: cm 550x140. Finitura: F32/C  
Design Centro Ricerche MAMM  
**PESO:** 110 kg - m<sup>3</sup>: 2 - **COLLI:** 5

**MEASURES:** L 190 W 216 H 112  
**DESCRIPTION:** *bed with storage compartment made of cherry wood and leather. Upholstered headboard with wooden helical turned profile. Folding wooden slats mattress support. Required fabric: cm 550x140 Finishing: F32/C.*  
Design by centro Ricerche MAMM  
**WEIGHT:** 110 kg - m<sup>3</sup>: 2 - **PIECES:** 5

ART. 2891  
LETTO VALENTINO CON BALDACCHINO

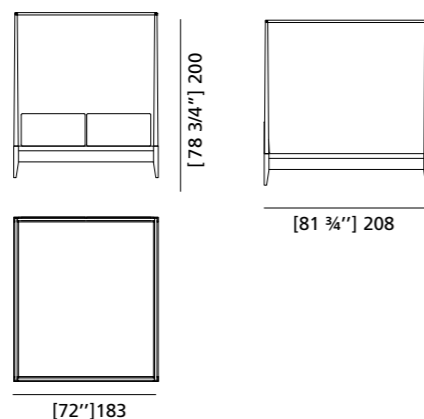

**MISURE:** L 183 P 208 H 200  
**DESCRIZIONE:** letto in legno di ciliegio con testiera imbottita in pelle o tessuto e struttura a baldacchino. Supporto in doghe di legno. Tessuto occorrente: cm 250x140.  
Design Centro Ricerche MAMM  
**PESO:** 100 kg - m<sup>3</sup>: 1 **COLLI:** 5

**MEASURES:** L 183 W 208 H 200  
**DESCRIPTION:** *bed made of cherry wood with fabric or leather upholstered headboard and baldachin. Wooden slats mattress support. Required fabric: cm 250x140.*  
Design by centro Ricerche MAMM  
**WEIGHT:** 100 kg - m<sup>3</sup>: 1 **PIECES:** 5

ART. 2850  
LETTO RULMAN

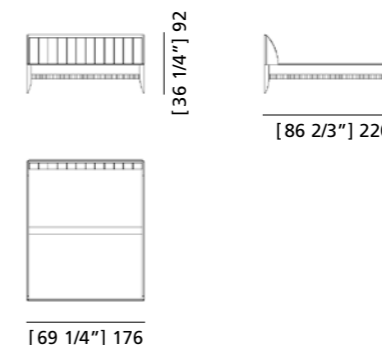

**MISURE:** L 176 P 220 H 92  
**DESCRIZIONE:** letto in legno di ciliegio con pregiata fresatura delle sponde e testiera imbottita bifacciale. Supporto in doghe di legno  
Tessuto occorrente: cm 260x140. Finitura: F60  
Design Centro Ricerche MAMM  
**VANO INTERNO:** L 170 P 195  
**PESO:** 95 kg - m<sup>3</sup>: 1,05 - **COLLI:** 4

**MEASURES:** L 176 W 220 H 92  
**DESCRIPTION:** *bed made of cherry wood with fine milling on the lower profiles of the sides and upholstered double face headboard. Wooden slats mattress support. Wooden slats mattress support. Required fabric: cm 260x140. Finishing: F60*  
Design by centro Ricerche MAMM  
**INTERNAL SIZE:** L 170 W 195  
**WEIGHT:** 95 kg - m<sup>3</sup>: 1,05 - **PIECES:** 4

ART. 2885  
LETTO UMBERTO

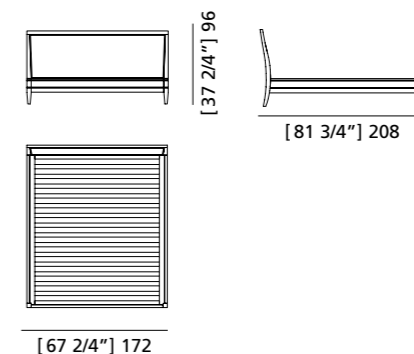

**MISURE:** L 172 P 208 H 96  
**DESCRIZIONE:** letto con struttura in legno di ciliegio, imbottita e rivestita come la testiera in pelle o tessuto. Supporto in doghe di legno. Tessuto occorrente: cm 390x140. Finitura: F34  
Design Centro Ricerche MAMM  
**PESO:** 67 kg - m<sup>3</sup>: 1 - **COLLI:** 4

**MEASURES:** L 172 W 208 H 96  
**DESCRIPTION:** *bed made of cherry wood with upholstered headboard and sides. Wooden slats mattress support. Required fabric: cm 390x140. Finishing: F34*  
Design by centro Ricerche MAMM  
**WEIGHT:** 67 kg - m<sup>3</sup>: 1 - **PIECES:** 4

ART. 2886  
LETTO UMBERTO

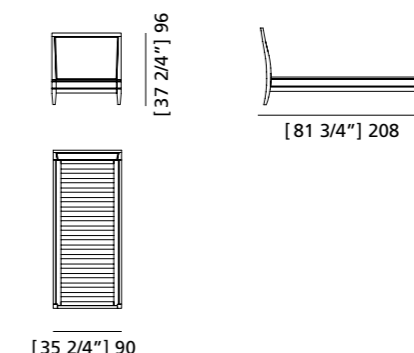

**MISURE:** L 90 P 208 H 96  
(Disponibile con misure: L 120)  
**DESCRIZIONE:** letto con struttura in legno di ciliegio, imbottita e rivestita come la testiera in pelle o tessuto. Supporto in doghe di legno. Tessuto occorrente: cm 250x140. Finitura: F34  
Design Centro Ricerche MAMM  
**PESO:** 46 kg - m<sup>3</sup>: 0,5 - **COLLI:** 3

**MEASURES:** L 90 W 208 H 96  
(available with meusers: L 120)  
**DESCRIPTION:** *bed made of cherry wood with upholstered headboard and sides. Wooden slats mattress support. Required fabric: cm 250x140. Finishing: F34*  
Design by centro Ricerche MAMM  
**WEIGHT:** 46 kg - m<sup>3</sup>: 0,5 - **PIECES:** 3

ART. 2873  
LETTO BIEDERMEIER

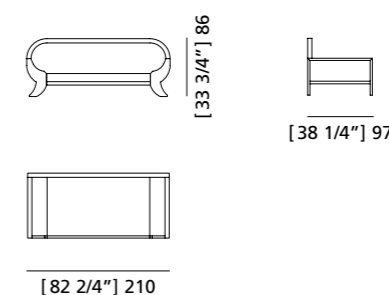

**MISURE:** L 210 P 97 H 86  
**DESCRIZIONE:** letto con schienale e struttura in legno di ciliegio e profilo inferiore intarsiato in legno di ebano. Supporto in doghe di legno. Finitura: F34  
Design Centro Ricerche MAMM  
**VANO INTERNO:** L 90 P 195  
**PESO:** 65 kg - m<sup>3</sup>: 0,5 - **COLLI:** 4

**MEASURES:** L 210 W 97 H 86  
**DESCRIPTION:** *bed with backrest made of cherry wood with ebony inlay in the lower profile. Wooden slats mattress support. Finishing: F34*  
Design by centro Ricerche MAMM  
**INTERNAL SIZE:** L 90 W 195  
**WEIGHT:** 65 kg - m<sup>3</sup>: 0,5 - **PIECES:** 4

ART. 2874  
LETTO BIEDERMEIER

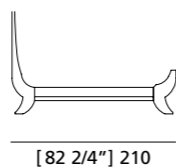
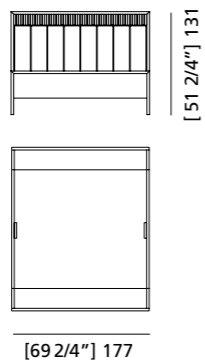

MISURE: L 177 P 210 H 131  
DESCRIZIONE: letto con struttura in legno di ciliegio e profilo inferiore intarsiato in legno di palissandro. Testiera imbottita in pelle o tessuto con pregiata fresatura a lesene. Supporto in doghe di legno. Tessuto occorrente: cm 240x140. Finitura: F34. Design Centro Ricerche MAMM  
VANO INTERNO: L 170 P 195  
PESO: 125 kg - m<sup>3</sup>: 1,2 - COLLI: 4  
MEASURES: L 177 W 210 H 131  
DESCRIPTION: bed made of cherry wood with rosewood inlay in the lower profile. Headboard upholstered in leather or fabric with a precious milling. Wooden slats mattress support. Required fabric: cm 240x140. Finishing: F34  
Design by centro Ricerche MAMM  
INTERNAL SIZE: L 170 W 195  
WEIGHT: 125 kg - m<sup>3</sup>: 1,2 - PIECES: 4

ART. 2822  
LETTO LUIGI FILIPPO

| IN ELIMINAZIONE |

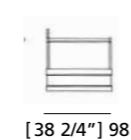
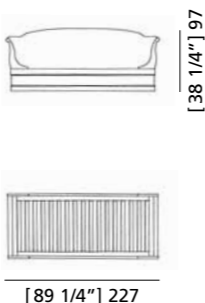

MISURE: L 98 P 227 H 97  
DESCRIZIONE: letto in legno di ciliegio con testiera e pediera in legno. Secondo letto singolo estraibile a cassetto. 2 supporti in doghe di legno. Finitura: F60. Design Centro Ricerche MAMM  
VANO INTERNO 1° LETTO: L 90 P 195  
INGOMBRO 2° LETTO: L 85 P 203  
VANO INTERNO 2° LETTO: L 80 P 190  
PESO: 113 kg - m<sup>3</sup>: 1 - COLLI: 4  
MEASURES: L 98 W 227 H 97  
DESCRIPTION: bed made of cherry wood with wooden headboard, footboard and backrest. Second extractable bed. 2 wooden slats mattress supports. Finishing: F60. Design by centro Ricerche MAMM  
INTERNAL SIZE 1ST BED: L 90 W 195  
SIZE SPARE BED: L 85 W 203  
INTERNAL SIZE SPARE BED: L 80 W 190  
WEIGHT: 113 kg - m<sup>3</sup>: 1 - PIECES: 4

ART. 2821  
LETTO LUIGI FILIPPO



MISURE: L 98 P 227 H 91  
DESCRIZIONE: letto in legno di ciliegio con testiera, pediera e schienale in legno e gambette sagomate. Supporto in doghe di legno. Finitura: F60. Design Centro Ricerche MAMM  
VANO INTERNO: L 90 P 195  
PESO: 74 kg - m<sup>3</sup>: 0,85 - COLLI: 4  
MEASURES: L 98 W 227 H 91  
DESCRIPTION: bed made of cherry wood with wooden headboard, footboard and backrest; shaped legs. Wooden slats mattress support. Finishing: F60  
Design by centro Ricerche MAMM  
INTERNAL SIZE: L 90 W 195  
WEIGHT: 74 kg - m<sup>3</sup>: 0,85 - PIECES: 4

ART. 2847  
LETTO DIRETTORIO

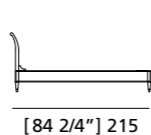
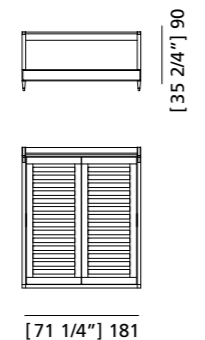

MISURE: L 181 P 215 H 90  
DESCRIZIONE: letto in legno di ciliegio con testiera sagomata. Su richiesta con testiera imbottita. Supporto in doghe di legno. Finitura: F34. Design Centro Ricerche MAMM  
VANO INTERNO: L 170 P 195  
PESO: 80 kg - m<sup>3</sup>: 1 - COLLI: 3  
MEASURES: L 181 W 215 H 90  
DESCRIPTION: bed made of cherry wood with wooden headboard; carved legs. Wooden slats mattress support. Upon request with upholstered headboard. Finishing: F34  
Design by centro Ricerche MAMM  
INTERNAL SIZE: L 170 W 195  
WEIGHT: 80 kg - m<sup>3</sup>: 1 - PIECES: 3

ART. 5002/F  
SCRITTOIO BELLAGIO

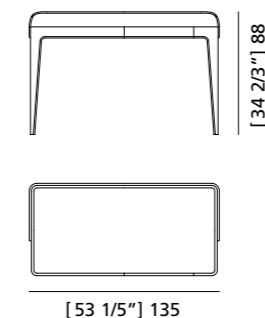

MISURE: L 135 P 66 H 88  
DESCRIZIONE: Scrivania in legno di frassino con piano in pelle e cassetto porta oggetti. Design Libero Rutilo.  
PESO: 55 kg - m<sup>3</sup>: 1 - COLLI: 1

MEASURES: L 135 W 66 H 88  
DESCRIPTION: Writing desk made of ash wood with leather top and one drawer. Design by Libero Rutilo.  
WEIGHT: 55 kg - m<sup>3</sup>: 1 - PIECES: 1

ART. 5003/F  
SCRITTOIO SWING

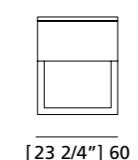
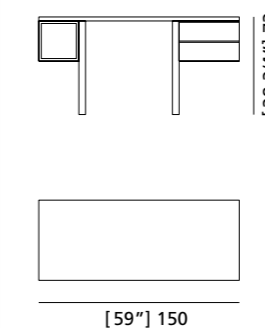

MISURE: L 150 P 60 H 73  
DESCRIZIONE: Scrivania in legno di frassino, due cassetti a destra, un vano a giorno a sinistra. Sul retro due vani a giorno. Interni colorati. Finitura F32/F. Design Libero Rutilo  
PESO: 45 kg - m<sup>3</sup>: 0,65 - COLLI: 1

MEASURES: L 150 P 60 H 73  
DESCRIPTION: Desk in ash wood with 2 drawers and open elements on left and back. Finitura F32/F. Design Libero Rutilo  
WEIGHT: 45 kg - m<sup>3</sup>: 0,65 - PIECES: 1

ART. 5080  
SCRITTOIO EUGENIO

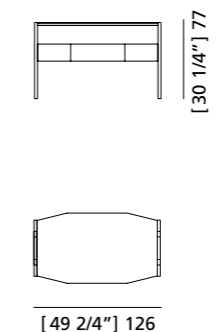

MISURE: L 126 P 70 H 77  
DESCRIZIONE: Scrivania in legno di ciliegio con piano ottagonale e due cassetti laterali con vano a giorno. Design Centro Ricerche MAMM  
PESO: 43 kg - m<sup>3</sup>: 0,9  
COLLI: 1

MEASURES: L 126 W 70 H 77  
DESCRIPTION: Writing desk made of cherry wood with octagonal top, 2 drawers and open space. Design by centro Ricerche MAMM  
WEIGHT: 43 kg - m<sup>3</sup>: 0,9  
PIECES: 1

ART. 5052  
SCRITTOIO '900 PORTA PC / PORTA TV

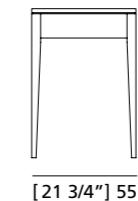
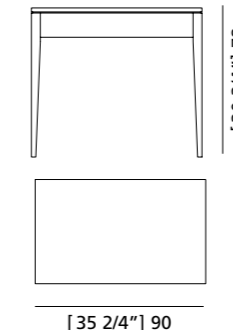

MISURE: L 90 P 55 H 78  
DESCRIZIONE: tavolino - scrivania porta PC con cassetto centrale e frontale a ribalta, vano passacavi posteriore e due tiri a scomparsa sui fianchi. Finitura: F32/C. Design Centro Ricerche MAMM  
PESO: 40 kg - m<sup>3</sup>: 0,53  
COLLI: 1

MEASURES: L 90 W 55 H 78  
DESCRIPTION: writing desk made of cherry wood with 1 flap opening drawer. Suitable for a PC. Finishing: F32/C. Design by centro Ricerche MAMM  
WEIGHT: 40 kg - m<sup>3</sup>: 0,53  
PIECES: 1



COMÒ  
CASSETTIERE

COMÒ  
CHEST OF DRAWERS

ART. 1203/F  
COMO' JOYCE

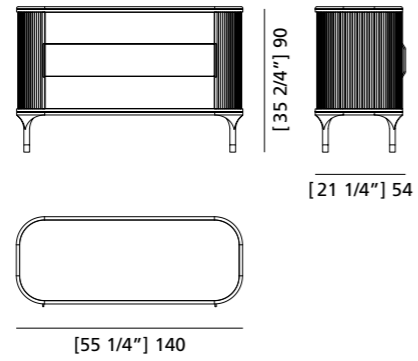

MISURE: L 140 P 54 H 90  
DESCRIZIONE: Comò in legno di frassino con piano in marmo, tre cassetti a scomparsa e due ante scorrevoli laterali con maniglie in ottone, ripiano interno. Piedino sagomato con bicchierino in ottone.  
Design Libero Rutilo  
PESO: 90 kg - m<sup>3</sup>: 0,7 - COLLI: 1

MEASURES: L 140 P 54 H 90  
DESCRIPTION: Ash wood dresser with marble top, three hidden drawers and two side sliding doors with brass handles, internal shelf. Shaped foot with brass cup.  
Design Libero Rutilo  
WEIGHT: 90 kg - m<sup>3</sup>: 0,7 - PIECES: 1

ART. 1303/F  
COMODINO JOYCE

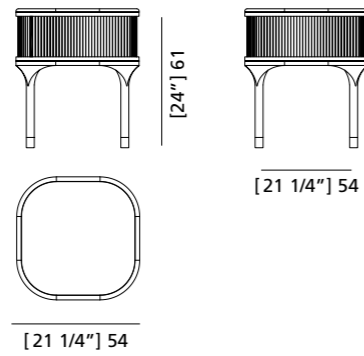

MISURE: L 54 P 54 H 61  
DESCRIZIONE: Comodino in legno di frassino, un vano chiuso da antina scorrevole, maniglia in ottone. Piedini sagomati con bicchierino in ottone.  
Design Libero Rutilo  
PESO: 20 kg - m<sup>3</sup>: 0,2 - COLLI: 1

MEASURES: L 54 P 54 H 61  
DESCRIPTION: Ash wood bedside table, a compartment closed by a sliding door, brass handle. Shaped feet with brass cup.  
Design Libero Rutilo  
WEIGHT: 20 kg - m<sup>3</sup>: 0,2 - PIECES: 1

ART. 1202/F  
COMO' BELLAGIO

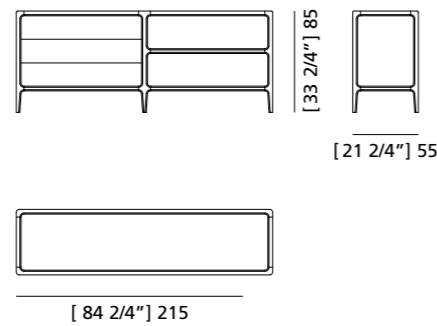
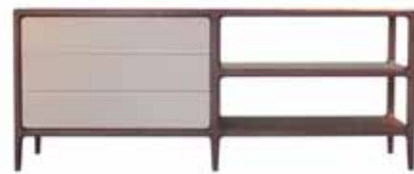

MISURE: L 215 P 55 H 85  
DESCRIZIONE: Comò in legno di frassino, cassetti rivestiti in pelle, ripiano in vetro.  
Design Libero Rutilo  
PESO: 100 kg - m<sup>3</sup>: 1,0 - COLLI: 1

MEASURES: L 140 P 54 H 90  
DESCRIPTION: Chest of drawer made of ash wood with three drawers and open element. Top and drawers can be of wood, leather or marble.  
Design Libero Rutilo  
WEIGHT: 100 kg - m<sup>3</sup>: 1,0 - PIECES: 1

ART. 1302/F  
COMODINO BELLAGIO

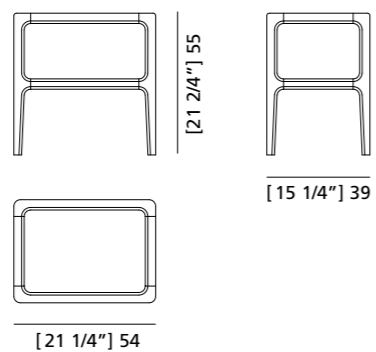

MISURE: L 54 P 39 H 55  
DESCRIZIONE: Comodino in legno di frassino con un cassetto.  
Design Libero Rutilo  
PESO: 20 kg - m<sup>3</sup>: 0,1 - COLLI: 1

MEASURES: L 54 P 39 H 55  
DESCRIPTION: Bedside table made of ash wood with one drawer. Top and drawer can be of wood, leather or marble.  
Design Libero Rutilo  
WEIGHT: 20 kg - m<sup>3</sup>: 0,1 - PIECES: 1

ART. 1201/F  
COMO' BELLAGIO

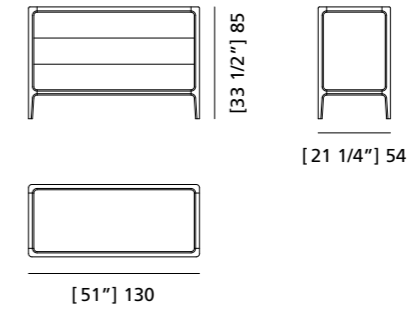

MISURE: L 130 P 54 H 85  
DESCRIZIONE: Comò in legno di frassino con tre cassetti.  
Design: Libero Rutilo  
PESO: 80 kg - m<sup>3</sup>: 0,8 - COLLI: 1

MEASURES: L 130 P 54 H 85  
DESCRIPTION: Chest of drawer made of ash wood with three drawers.  
Design: Libero Rutilo  
WEIGHT: 80 kg - m<sup>3</sup>: 0,8 - PIECES: 1

ART. 1301/F  
COMODINO BELLAGIO

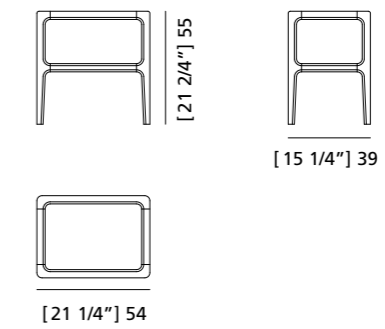

MISURE: L 54 P 39 H 55  
DESCRIZIONE: Comodino in legno di frassino con due ripiani in vetro.  
Design: Libero Rutilo  
PESO: 15 kg - m<sup>3</sup>: 0,15 - COLLI: 1

MEASURES: L 54 P 39 H 55  
DESCRIPTION: Bedside table made of ash wood with two glass shelves.  
Design: Libero Rutilo  
WEIGHT: 15 kg - m<sup>3</sup>: 0,15 - PIECES: 1

ART. 1269/F  
COMO' ANERIO

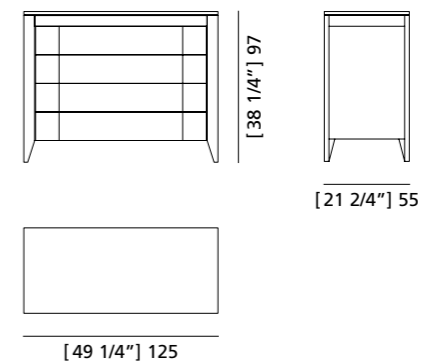

MISURE: L 125 P 55 H 97  
DESCRIZIONE: comò in legno di frassino a 4 cassetti più 1 cassetto nascosto sotto il piano. Fronte dei cassetti a venatura contrapposta tra parti in rilievo.  
Design Centro Ricerche MAM  
PESO: 84 kg - m<sup>3</sup>: 0,8 - COLLI: 1

MEASURES: L 125 W 55 H 97  
DESCRIPTION: chests of drawers made of ash wood with 4 drawers plus 1 hidden drawer under the top. Drawer fronts with opposed grain and different reliefs.  
Design by centro Ricerche MAM  
WEIGHT: 84 kg - m<sup>3</sup>: 0,8 - PIECES: 1

ART. 1366/F  
COMODINO ANERIO

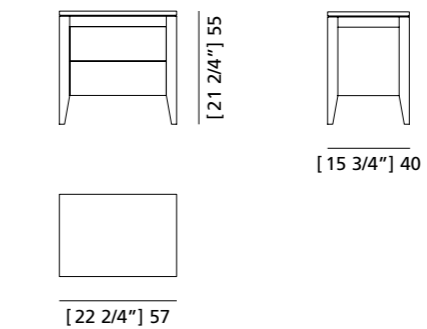

MISURE: L 57 P 40 H 55  
DESCRIZIONE: comodino in legno di frassino a 2 cassetti. Fronte dei cassetti a venatura contrapposta tra parti in rilievo.  
Design Centro Ricerche MAM  
PESO: 24 kg - m<sup>3</sup>: 0,16 - COLLI: 1

MEASURES: L 57 W 40 H 55  
DESCRIPTION: bedside table made of ash wood with 2 drawers. Drawer fronts with opposed grain and different reliefs.  
Design by centro Ricerche MAM  
WEIGHT: 24 kg - m<sup>3</sup>: 0,16 - PIECES: 1

ART. 1268  
COMÒ VITTORIO

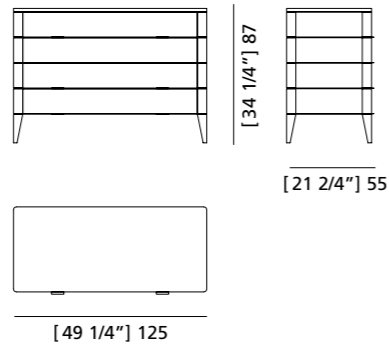

**MISURE:** L 125 P 55 H 87  
**DESCRIZIONE:** comò a 4 cassetti in legno di ciliegio con maniglie in ottone. Gambe a stiletto con particolare fresatura sui fianchi. Su richiesta in legno di noce canaletto. Finitura: F32/C.  
Design Centro Ricerche MAMM  
**PESO:** 80 kg - m<sup>3</sup>: 0,75 - **COLLI:** 1

**MEASURES:** L 125 W 55 H 87  
**DESCRIPTION:** chest of drawers made of cherry wood with brass handles over the 4 drawers. Fine milling on the sides along the drawers cut. Upon request made of walnut. Finishing: F32/C.  
Design by centro Ricerche MAMM  
**WEIGHT:** 80 kg - m<sup>3</sup>: 0,75 - **PIECES:** 1

ART. 1365  
COMODINO VITTORIO

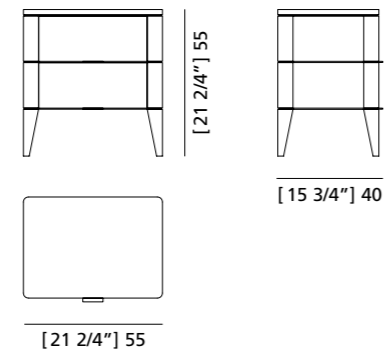

**MISURE:** L 55 P 40 H 55  
**DESCRIZIONE:** comodino a 2 cassetti in legno di ciliegio con maniglie in ottone. Gambe a stiletto con particolare fresatura sui fianchi. Su richiesta in legno di noce canaletto. Finitura: F32/C.  
Design Centro Ricerche MAMM  
**PESO:** 24 kg - m<sup>3</sup>: 0,18 - **COLLI:** 1

**MEASURES:** L 55 W 40 H 55  
**DESCRIPTION:** bedside table made of cherry wood with brass handles over the 2 drawers. Fine milling on the sides along the drawers cut. Upon request made of walnut wood. Finishing: F32/C.  
Design by centro Ricerche MAMM  
**WEIGHT:** 24 kg - m<sup>3</sup>: 0,18 - **PIECES:** 1

ART. 1204  
COMÒ SCACCHI

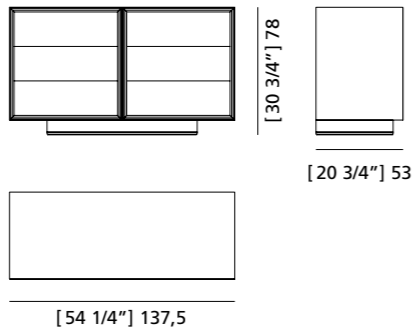

**MISURE:** L 137,5 P 53 H 78  
**DESCRIZIONE:** Comò a sei cassetti con struttura in legno di ciliegio. Finitura: F32/C.  
Design: Centro Ricerche MAMM  
**PESO:** 80 kg - m<sup>3</sup>: 0,60 - **COLLI:** 1

**MEASURES:** L 137,5 P 53 H 78  
**DESCRIPTION:** Chest of drawers in cherry wood with 6 drawers. Finishing: F32/C.  
Design: Centro Ricerche MAMM  
**WEIGHT:** 80 kg - m<sup>3</sup>: 0,60 - **PIECES:** 1

ART. 1357  
COMODINO SCACCHI

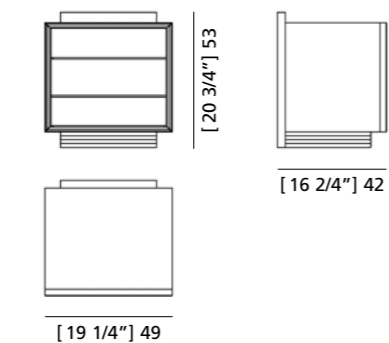

**MISURE:** L 49 P 42 H 53  
**DESCRIZIONE:** comodino a 3 cassetti della collezione Zero con struttura in legno di ciliegio e basamento con frontale intagliato.  
Design Centro Ricerche MAMM  
**PESO:** 22 kg - m<sup>3</sup>: 0,15 - **COLLI:** 1

**MEASURES:** L 49 W 42 H 53  
**DESCRIPTION:** bedside table with 3 drawers from the Zero collection made of cherry wood and base with carved front. Design by centro Ricerche MAMM  
**WEIGHT:** 22 kg - m<sup>3</sup>: 0,15 - **PIECES:** 1

ART. 1273  
COMÒ FEDELE

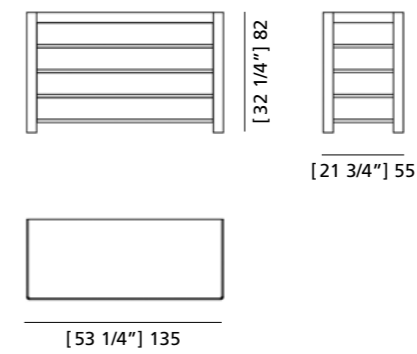

**MISURE:** L 135 P 55 H 82  
**DESCRIZIONE:** Comò a quattro cassetti in legno di ciliegio con frontali e fianchi rivestiti in pelle.  
Design Centro Ricerche MAMM  
**PESO:** 80 kg - m<sup>3</sup>: 0,8 - **COLLI:** 1

**MEASURES:** L 135 W 55 H 82  
**DESCRIPTION:** Chest of drawer made of cherry wood with four drawers and sides covered with leather.  
Design by centro Ricerche MAMM  
**WEIGHT:** 80 kg - m<sup>3</sup>: 0,8 - **PIECES:** 1

ART. 1368  
COMODINO FEDELE

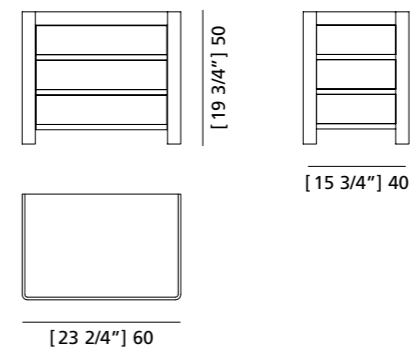

**MISURE:** L 60 P 40 H 50  
**DESCRIZIONE:** Comodino a tre cassetti in legno di ciliegio con frontali e fianchi rivestiti in pelle.  
Design Centro Ricerche MAMM  
**PESO:** 25 kg - m<sup>3</sup>: 0,2 - **COLLI:** 1

**MEASURES:** L 60 W 40 H 50  
**DESCRIPTION:** Bedside table made of cherry wood with three drawers and sides covered with leather.  
Design by centro Ricerche MAMM  
**WEIGHT:** 25 kg - m<sup>3</sup>: 0,2 - **PIECES:** 1

ART. 1272/F  
COMÒ MALIBÙ

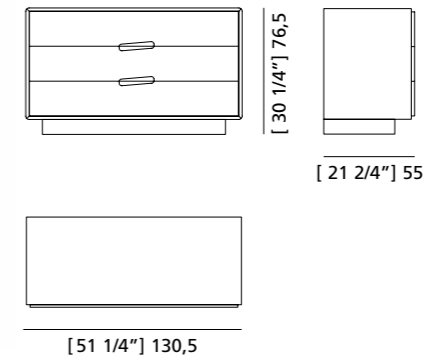

**MISURE:** L 130,5 P 55 H 76,5  
**DESCRIZIONE:** comò a 3 cassetti in legno di frassino, con guide metalliche. Particolare la struttura ad angoli smussati e le maniglie intagliate in diagonale.  
Design Centro Ricerche MAMM  
**PESO:** 73 kg - m<sup>3</sup>: 0,65 - **COLLI:** 1

**MEASURES:** L 130,5 W 55 H 76,5  
**DESCRIPTION:** chest of drawers made of ash wood, with 3 drawers on metal runners. Precious structure with rounded corners and diagonally carved handles. Design by centro Ricerche MAMM  
**WEIGHT:** 73 kg - m<sup>3</sup>: 0,65 - **PIECES:** 1

ART. 1367/F  
COMODINO MALIBÙ

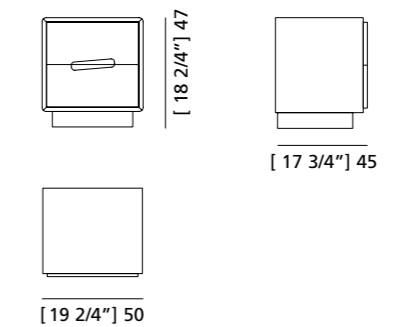

**MISURE:** L 50 P 45 H 47  
**DESCRIZIONE:** comodino a 2 cassetti in legno di frassino, con guide metalliche. Particolare la struttura ad angoli smussati e le maniglie intagliate in diagonale.  
Design Centro Ricerche MAMM  
**PESO:** 27 kg - m<sup>3</sup>: 0,15 - **COLLI:** 1

**MEASURES:** L 50 W 45 H 47  
**DESCRIPTION:** bedside table made of ash wood, with 2 drawers on metal runners. Precious structure with rounded corners and diagonally carved handle. Design by centro Ricerche MAMM  
**WEIGHT:** 27 kg - m<sup>3</sup>: 0,15 - **PIECES:** 1

ART. 1271  
COMÒ NEW YORK

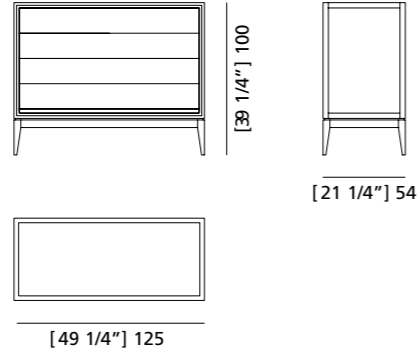

MISURE: L 125 P 54 H 100  
DESCRIZIONE: comò a 4 cassetti in legno di ciliegio con gambe a spillo e frontali dei cassetti spioventi, tipica lavorazione della collezione '900. Finitura: F30  
Design Centro Ricerche MAMM  
PESO: 70 kg - m<sup>3</sup>: 0,8 - COLLI: 1

MEASURES: L 125 W 54 H 100  
DESCRIPTION: chest of drawers made of cherry wood with 4 drawers with sloping front, typical processing of the '900 collection. Finishing: F30  
Design by centro Ricerche MAMM  
WEIGHT: 70 kg - m<sup>3</sup>: 0,8 - PIECES: 1

ART. 1254  
COMÒ NEW YORK

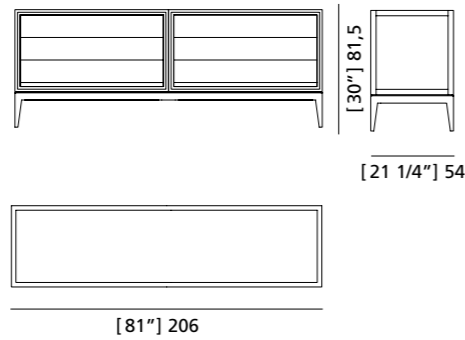

MISURE: L 206 P 54 H 81,5  
DESCRIZIONE: comò a 6 cassetti in legno di ciliegio con gambe a spillo e frontali dei cassetti spioventi, tipica lavorazione della collezione '900. Finitura: F30  
Design Centro Ricerche MAMM  
PESO: 98 kg - m<sup>3</sup>: 0,95 - COLLI: 1

MEASURES: L 206 W 54 H 81,5  
DESCRIPTION: chest of drawers made of cherry wood with 6 drawers with sloping front, typical processing of the '900 collection. Finishing: F30  
Design by centro Ricerche MAMM  
WEIGHT: 98 kg - m<sup>3</sup>: 0,95 - PIECES: 1

ART. 1253  
COMÒ NEW YORK

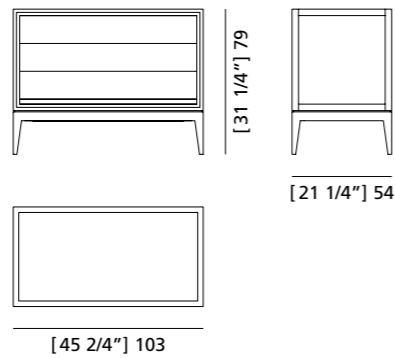

MISURE: L 103 P 54 H 79  
DESCRIZIONE: Comò in legno di ciliegio, tre cassetti con frontali spioventi, tipica lavorazione dello stile '900, gambe a spillo. Finitura: F32/C  
Design: Centro Ricerche MAMM  
PESO: 70 kg - m<sup>3</sup>: 0,50 - COLLI: 1

MEASURES: L 103 P 54 H 79  
DESCRIPTION: Chest of drawers made of cherry wood. Finishing F32/C  
Design: Centro Ricerche MAMM  
WEIGHT: 70 kg - m<sup>3</sup>: 0,50 - PIECES: 1

ART. 1361  
COMODINO NEW YORK

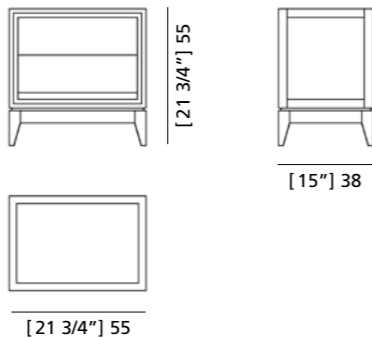

MISURE: L 55 P 38 H 55  
DESCRIZIONE: comodino a 2 cassetti in legno di ciliegio con gambe a spillo e frontali dei cassetti spioventi, tipica lavorazione della collezione '900. Finitura: F30  
Design Centro Ricerche MAMM  
PESO: 20 kg - m<sup>3</sup>: 0,16  
COLLI: 1

MEASURES: L 55 W 38 H 55  
DESCRIPTION: bedside table made of cherry wood with 2 drawers with sloping front, typical processing of the '900 collection. Finishing: F30  
Design by centro Ricerche MAMM  
WEIGHT: 20 kg - m<sup>3</sup>: 0,16 - PIECES: 1

ART. 0801  
CASSETTIERA NEW YORK

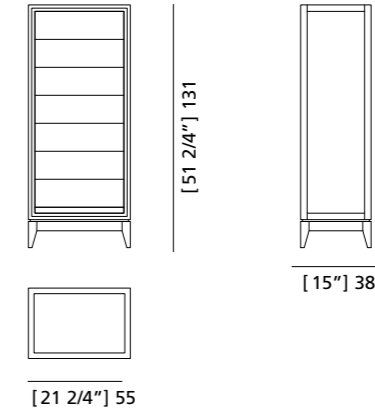

MISURE: L 55 P 38 H 131  
DESCRIZIONE: cassetiera a 7 cassetti in legno di ciliegio con gambe a spillo e frontali dei cassetti spioventi, tipica lavorazione della collezione '900. Finitura: F32/C  
Design Centro Ricerche MAMM  
PESO: 30 kg - m<sup>3</sup>: 0,5 - COLLI: 1

MEASURES: L 55 W 38 H 131  
DESCRIPTION: chest of drawers made of cherry wood with 7 drawers with sloping front, typical processing of the '900 collection. Finishing: F32/C  
Design by centro Ricerche MAMM  
WEIGHT: 30 kg - m<sup>3</sup>: 0,5 - PIECES: 1

ART. 1257  
COMÒ RULMAN

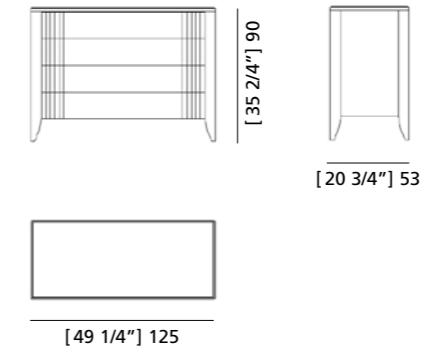

MISURE: L 125 P 53 H 90  
DESCRIZIONE: Comò a 4 cassetti in legno di ciliegio con pregiata venatura e controfresatura a lesene sui lati dei cassetti. Finitura: F60  
Design Centro Ricerche MAMM  
PESO: 77 kg - m<sup>3</sup>: 0,78 - COLLI: 1

MEASURES: L 125 W 53 H 90  
DESCRIPTION: Chest of drawers made of cherry wood with prestigious veneer on the surfaces and fine milling on the drawers sides. Finishing: F60  
Design by centro Ricerche MAMM  
WEIGHT: 77 kg - m<sup>3</sup>: 0,78 - PIECES: 1

ART. 1356  
COMODINO RULMAN

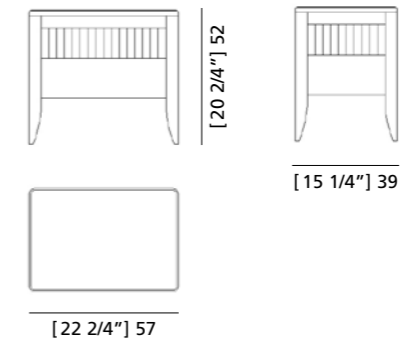

MISURE: L 57 P 39 H 52  
DESCRIZIONE: comodino a 2 cassetti in legno di ciliegio con pregiata venatura e controfresatura a lesene sul cassetto superiore. Finitura: F60  
Design Centro Ricerche MAMM  
PESO: 22 kg - m<sup>3</sup>: 0,16 - COLLI: 1

MEASURES: L 57 W 39 H 52  
DESCRIPTION: bedside table made of cherry wood with prestigious veneer on the surfaces and fine milling on the upper drawer. Finishing: F60  
Design by centro Ricerche MAMM  
WEIGHT: 22 kg - m<sup>3</sup>: 0,16 - PIECES: 1

ART. 0830  
CASSETTIERA RULMAN

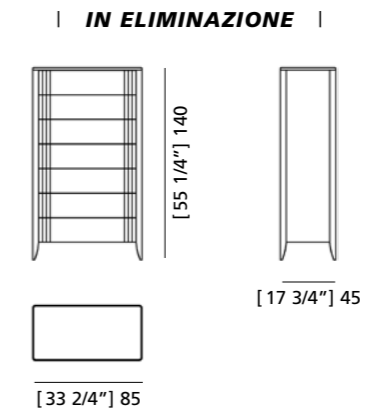

MISURE: L 85 P 45 H 140  
DESCRIZIONE: Comò a 7 cassetti in legno di ciliegio con pregiata venatura e controfresatura a lesene sui lati dei cassetti. Finitura: F60  
Design Centro Ricerche MAMM  
PESO: 72 kg - m<sup>3</sup>: 0,62 - COLLI: 1

MEASURES: L 85 W 45 H 140  
DESCRIPTION: chest of 7 drawers made of cherry wood with prestigious veneer on the surfaces and fine milling on the drawers sides. Upon request made of Canaletto walnut wood. Finishing: F60  
Design by centro Ricerche MAMM  
WEIGHT: 72 kg - m<sup>3</sup>: 0,62 - PIECES: 1



ART. 1258  
COMÒ BIEDERMEIER



[33 3/4"] 86



[21 1/4"] 54



[54 1/4"] 138

MISURE: L 138 P 54 H 86  
DESCRIZIONE: comò in legno di ciliegio con fresatura a lesene sui 4 cassetti e pregiato intarsio in ebano.  
Finitura: F34  
Design Centro Ricerche   
PESO: 90 kg - m<sup>3</sup>: 0,84 - COLLI: 1

MEASURES: L 138 W 54 H 86  
DESCRIPTION: chest of drawers made of cherry wood with prestigious milling on the 4 drawers and ebony inlay.  
Finishing: F34  
Design by centro Ricerche   
WEIGHT: 90 kg - m<sup>3</sup>: 0,84 - PIECES: 1

ART. 1362  
COMODINO BIEDERMEIER



[23 2/4"] 60

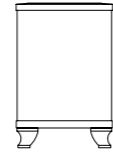

[15 3/4"] 40

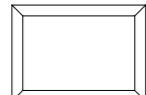

[22"] 56

MISURE: L 56 P 40 H 60  
DESCRIZIONE: comodino in legno di ciliegio con fresatura a lesene sui 3 cassetti e pregiato intarsio in ebano.  
Finitura: F34  
Design Centro Ricerche   
PESO: 26 kg - m<sup>3</sup>: 0,17 - COLLI: 1

MEASURES: L 56 W 40 H 60  
DESCRIPTION: bedside table made of cherry wood with prestigious milling on the 3 drawers and ebony inlay.  
Finishing: F34  
Design by centro Ricerche   
WEIGHT: 26 kg - m<sup>3</sup>: 0,17 - PIECES: 1

ART. 0831  
CASSETTIERA BIEDERMEIER

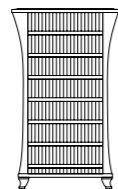

[55 1/4"] 140



[17 2/4"] 45

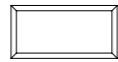

[35 2/4"] 90

MISURE: L 90 P 45 H 140  
DESCRIZIONE: comò in legno di ciliegio con fresatura a lesene sui 7 cassetti e pregiato intarsio in ebano.  
Finitura: F34  
Design Centro Ricerche   
PESO: 75 kg - m<sup>3</sup>: 0,7 - COLLI: 1

MEASURES: L 90 W 45 H 140  
DESCRIPTION: chest of drawers made of cherry wood with prestigious milling on the 7 drawers and ebony inlay.  
Finishing: F34  
Design by centro Ricerche   
WEIGHT: 75 kg - m<sup>3</sup>: 0,7 - PIECES: 1

ART. 5602  
TAVOLINO BIEDERMEIER



[26"] 66



[14 2/4"] 37



[26 2/4"] 67

MISURE: L 67 P 37 H 66  
DESCRIZIONE: tavolino rettangolare in legno di ciliegio. Piano con profilo diamantato e particolare fresatura a lesene sul frontale del cassetto. 1 ripiano sostenuto da gambe curvate. Finitura: F34  
Design Centro Ricerche   
PESO: 20 kg - m<sup>3</sup>: 0,30 - COLLI: 1

MEASURES: L 67 W 37 H 66  
DESCRIPTION: rectangular coffee table made of cherry wood. Top with diamond cut and fine milling on the front of the drawer. 1 shelf supported by curved legs.  
Finishing: F34  
Design by centro Ricerche   
WEIGHT: 20 kg - m<sup>3</sup>: 0,30 - PIECES: 1

ART. 1243  
COMÒ DIRETTORIO

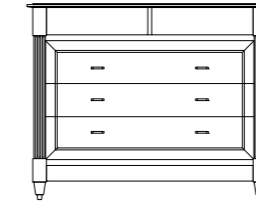

[39 1/4"] 100

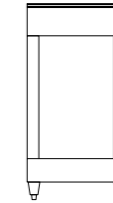

[21 1/4"] 54

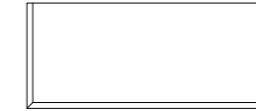

[49 1/4"] 125

MISURE: L 125 P 54 H 100  
DESCRIZIONE: Comò a 5 cassetti in legno di ciliegio. 3 cassetti con maniglie e 2 a scomparsa sotto il piano.  
Design Centro Ricerche   
PESO: 72 kg - m<sup>3</sup>: 0,8 - COLLI: 1

MEASURES: L 125 W 54 H 100  
DESCRIPTION: chest of drawers made of cherry wood with 3 big drawers and 2 small hidden drawers under the top. Fine milling on the sides and carved legs.  
Design by centro Ricerche   
WEIGHT: 72 kg - m<sup>3</sup>: 0,8 - PIECES: 1

ART. 1348  
COMODINO DIRETTORIO

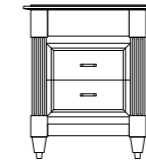

[25 1/4"] 64

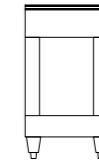

[15"] 38

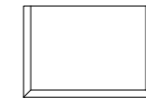

[21 1/4"] 54

MISURE: L 54 P 38 H 64  
DESCRIZIONE: comodino a 3 cassetti in legno di ciliegio. 2 cassetti con maniglie e 1 a scomparsa sotto il piano.  
Design Centro Ricerche   
PESO: 22 kg - m<sup>3</sup>: 0,15 - COLLI: 1

MEASURES: L 54 W 38 H 64  
DESCRIPTION: Bedside table made of cherry wood with 3 drawers. Fine milling on the sides and carved legs.  
Design by centro Ricerche   
WEIGHT: 22 kg - m<sup>3</sup>: 0,15 - PIECES: 1



ARMADI

WARDROBES

ART. 0362  
GUARDAROBA '900

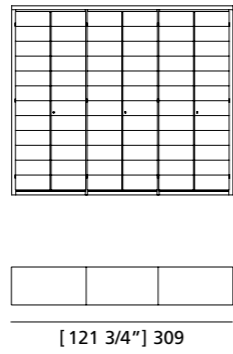

[104"] 264  
[23 1/4"] 59

[121 3/4"] 309

**MISURE:** L 309 P 59 H 264  
**DESCRIZIONE:** armadio guardaroba a 6 ante in legno di ciliegio con pregiata impiallacciatura a venature disallineate. Interno: 5 ripiani regolabili e 5 aste appendiabiti. Accessori su richiesta: cassettiera a 3 cassetti, portacravatte, portapantaloni, cassaforte, appendiabiti inclinabile, specchio. Finitura: F30 Design Centro Ricerche **MAMM**.  
**PESO:** 330 kg - m<sup>3</sup>: 1,8 - **COLLI:** 10

**MEASURES:** L 309 W 59 H 264  
**DESCRIPTION:** wardrobe with 6 doors made of cherry wood with a fine grain misalignment. Inside: 5 adjustable shelves and 5 clothes rails. Accessories on request: chest of 3 drawers, tie rack, trouser rack, electronic safe, lifting hanging, rail mirror. Finishing: F30  
Design by centro Ricerche **MAMM**.  
**WEIGHT:** 330 kg - m<sup>3</sup>: 1,8 - **PIECES:** 10

ART. 0363  
GUARDAROBA '900

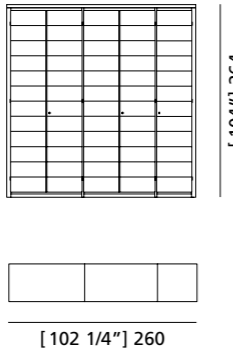

[104"] 264  
[23 1/4"] 59

[102 1/4"] 260

**MISURE:** L 260 P 59 H 264  
**DESCRIZIONE:** armadio guardaroba a 5 ante in legno di ciliegio con pregiata impiallacciatura a venature disallineate. Interno: 5 ripiani regolabili e 5 aste appendiabiti. Accessori su richiesta: cassettiera a 3 cassetti, portacravatte, portapantaloni, cassaforte, appendiabiti inclinabile, specchio. Finitura: F30 Design Centro Ricerche **MAMM**.  
**PESO:** 295 kg - m<sup>3</sup>: 1,7 - **COLLI:** 9

**MEASURES:** L 260 W 59 H 264  
**DESCRIPTION:** wardrobe with 5 doors made of cherry wood with a fine grain misalignment. Inside: 5 adjustable shelves and 5 clothes rails. Accessories on request: chest of 3 drawers, tie rack, trouser rack, electronic safe, lifting hanging, rail mirror. Finishing: F30  
Design by centro Ricerche **MAMM**.  
**WEIGHT:** 295 kg - m<sup>3</sup>: 1,7 - **PIECES:** 9

ART. 0364  
GUARDAROBA '900

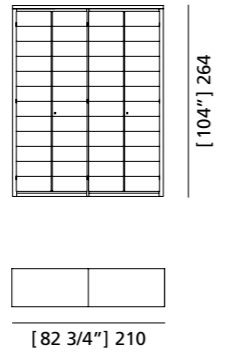

[104"] 264  
[23 1/4"] 59

[82 3/4"] 210

**MISURE:** L 210 P 59 H 264  
**DESCRIZIONE:** armadio guardaroba a 4 ante in legno di ciliegio con pregiata impiallacciatura a venature disallineate. Interno: 4 ripiani regolabili e 4 aste appendiabiti. Accessori su richiesta: cassettiera a 3 cassetti, portacravatte, portapantaloni, cassaforte, appendiabiti inclinabile, specchio. Finitura: F30 Design Centro Ricerche **MAMM**.  
**PESO:** 265 kg - m<sup>3</sup>: 1,5 - **COLLI:** 8

**MEASURES:** L 210 W 59 H 264  
**DESCRIPTION:** wardrobe with 4 doors made of cherry wood with a fine grain misalignment. Inside: 4 adjustable shelves and 4 clothes rails. Accessories on request: chest of 3 drawers, tie rack, trouser rack, electronic safe, lifting hanging, rail mirror. Finishing: F30  
Design by centro Ricerche **MAMM**.  
**WEIGHT:** 265 kg - m<sup>3</sup>: 1,5 - **PIECES:** 8

ART. 0365  
GUARDAROBA '900

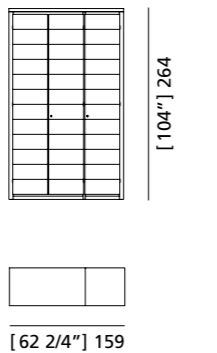

[104"] 264  
[23 1/4"] 59

[62 2/4"] 159

**MISURE:** L 159 P 59 H 264  
**DESCRIZIONE:** armadio guardaroba a 3 ante in legno di ciliegio con pregiata impiallacciatura a venature disallineate. Interno: 4 ripiani regolabili e 4 aste appendiabiti. Accessori su richiesta: cassettiera a 3 cassetti, portacravatte, portapantaloni, cassaforte, appendiabiti inclinabile, specchio. Finitura: F30 Design Centro Ricerche **MAMM**.  
**PESO:** 225 kg - m<sup>3</sup>: 1,2 - **COLLI:** 8

**MEASURES:** L 159 W 59 H 264  
**DESCRIPTION:** wardrobe with 3 doors made of cherry wood with a fine grain misalignment. Inside: 4 adjustable shelves and 4 clothes rails. Accessories on request: chest of 3 drawers, tie rack, trouser rack, electronic safe, lifting hanging, rail mirror. Finishing: F30  
Design by centro Ricerche **MAMM**.  
**WEIGHT:** 225 kg - m<sup>3</sup>: 1,2 - **PIECES:** 8

ART. 0366  
GUARDAROBA '900

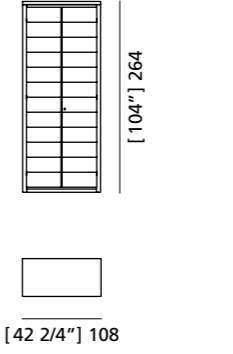

[104"] 264  
[23 1/4"] 59

[42 2/4"] 108

**MISURE:** L 108 P 59 H 264  
**DESCRIZIONE:** armadio guardaroba a 2 ante in legno di ciliegio con pregiata impiallacciatura a venature disallineate. Interno: 2 ripiani regolabili e 2 aste appendiabiti. Accessori su richiesta: cassettiera a 3 cassetti, portacravatte, portapantaloni, cassaforte, appendiabiti inclinabile, specchio. Finitura: F30 Design Centro Ricerche **MAMM**.  
**PESO:** 185 kg - m<sup>3</sup>: 1 - **COLLI:** 6

**MEASURES:** L 108 W 59 H 264  
**DESCRIPTION:** wardrobe with 2 doors made of cherry wood with a fine grain misalignment. Inside: 2 adjustable shelves and 2 clothes rails. Accessories on request: chest of 3 drawers, tie rack, trouser rack, electronic safe, lifting hanging, rail mirror. Finishing: F30  
Design by centro Ricerche **MAMM**.  
**WEIGHT:** 185 kg - m<sup>3</sup>: 1 - **PIECES:** 6

ART. 0327  
GUARDAROBA SCACCHI

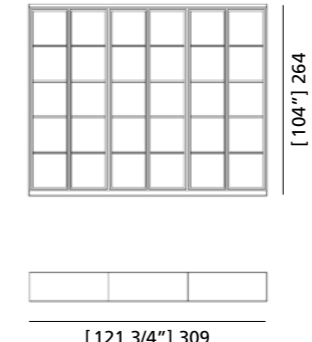

[104"] 264  
[23 1/4"] 59

[121 3/4"] 309

**MISURE:** L 309 P 59 H 264  
**DESCRIZIONE:** armadio guardaroba a 6 ante in legno di ciliegio con pregiata lavorazione a "scacchiera" e impiallacciatura a venature contrapposte. Interno: 5 ripiani regolabili e 5 aste appendiabiti. Accessori su richiesta: cassettiera a 3 cassetti, portacravatte, portapantaloni, cassaforte, appendiabiti inclinabile, specchio. Finitura: F30 Design Centro Ricerche **MAMM**.  
**PESO:** 330 kg - m<sup>3</sup>: 1,8 - **COLLI:** 10

**MEASURES:** L 309 W 59 H 264  
**DESCRIPTION:** wardrobe with 6 doors made of cherry wood with a fine checkerboard decoration. Inside: 5 adjustable shelves and 5 clothes rails. Accessories on request: chest of 3 drawers, tie rack, trouser rack, electronic safe, lifting hanging, rail mirror. Finishing: F30  
Design by centro Ricerche **MAMM**.  
**WEIGHT:** 330 kg - m<sup>3</sup>: 1,8 - **PIECES:** 10

ART. 0331  
GUARDAROBA SCACCHI

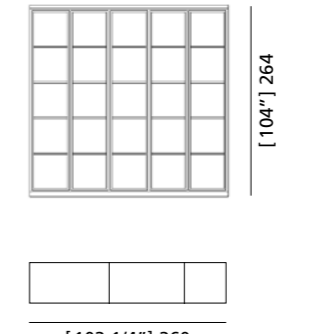

[104"] 264  
[23 1/4"] 59

[102 1/4"] 260

**MISURE:** L 260 P 59 H 264  
**DESCRIZIONE:** armadio guardaroba a 5 ante in legno di ciliegio con pregiata lavorazione a "scacchiera" e impiallacciatura a venature contrapposte. Interno: 5 ripiani regolabili e 5 aste appendiabiti. Accessori su richiesta: cassettiera a 3 cassetti, portacravatte, portapantaloni, cassaforte, appendiabiti inclinabile, specchio. Finitura: F30 Design Centro Ricerche **MAMM**.  
**PESO:** 295 kg - m<sup>3</sup>: 1,7 - **COLLI:** 9

**MEASURES:** L 260 W 59 H 264  
**DESCRIPTION:** Wardrobe with 5 doors made of cherry wood with a fine checkerboard decoration. Inside: 5 adjustable shelves and 5 clothes rails. Accessories on request: chest of 3 drawers, tie rack, trouser rack, electronic safe, lifting hanging, rail mirror. Finishing: F30  
Design by centro Ricerche **MAMM**.  
**WEIGHT:** 295 kg - m<sup>3</sup>: 1,7 - **PIECES:** 9

ART. 0332  
GUARDAROBA SCACCHI

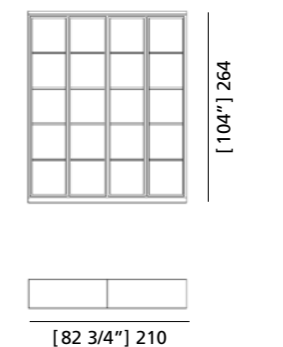

[104"] 264  
[23 1/4"] 59

[82 3/4"] 210

**MISURE:** L 210 P 59 H 264  
**DESCRIZIONE:** armadio guardaroba a 4 ante in legno di ciliegio con pregiata lavorazione a "scacchiera" e impiallacciatura a venature contrapposte. Interno: 4 ripiani regolabili e 4 aste appendiabiti. Accessori su richiesta: cassettiera a 3 cassetti, portacravatte, portapantaloni, cassaforte, appendiabiti inclinabile, specchio. Finitura: F30 Design Centro Ricerche **MAMM**.  
**PESO:** 275 kg - m<sup>3</sup>: 1,5 - **COLLI:** 8

**MEASURES:** L 210 W 59 H 264  
**DESCRIPTION:** wardrobe with 4 doors made of cherry wood with a fine checkerboard decoration. Inside: 4 adjustable shelves and 4 clothes rails. Accessories on request: chest of 3 drawers, tie rack, trouser rack, electronic safe, lifting hanging, rail mirror. Finishing: F30  
Design by centro Ricerche **MAMM**.  
**WEIGHT:** 275 kg - m<sup>3</sup>: 1,5 - **PIECES:** 8

ART. 0349  
GUARDAROBA SCACCHI

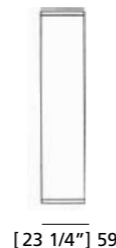
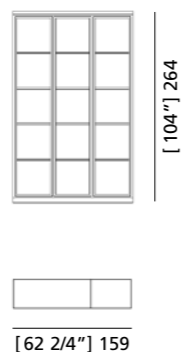

MISURE: L 159 P 59 H 264  
DESCRIZIONE: armadio guardaroba a 3 ante in legno di ciliegio con pregiata lavorazione a "scacchiera" e impiallacciatura a venature contrapposte. Interno: 4 ripiani regolabili e 4 aste appendiabiti. Accessori su richiesta: cassetiera a 3 cassetti, portacravatte, portapantaloni, cassaforte, appendiabiti inclinabile, specchio. Finitura: F30  
Design Centro Ricerche MAMM  
PESO: 225 kg - m<sup>3</sup>: 1,2 - COLLI: 8

MEASURES: L 159 W 59 H 264  
DESCRIPTION: wardrobe with 3 doors made of cherry wood with a fine checkerboard decoration. Inside: 4 adjustable shelves and 4 clothes rails. Accessories on request: chest of 3 drawers, tie rack, trouser rack, electronic safe, lifting hanging, rail mirror. Finishing: F30  
Design by centro Ricerche MAMM  
WEIGHT: 225 kg - m<sup>3</sup>: 1,2 - PIECES: 8

ART. 0348  
GUARDAROBA SCACCHI

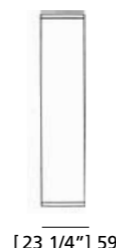
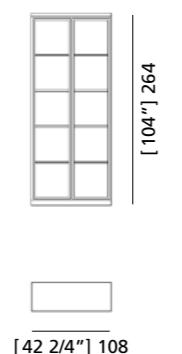

MISURE: L 108 P 59 H 264  
DESCRIZIONE: Armadio guardaroba a 2 ante in legno di ciliegio con pregiata lavorazione a "scacchiera" e impiallacciatura a venature contrapposte. Interno: 2 ripiani regolabili e 2 aste appendiabiti. Accessori su richiesta: cassetiera a 3 cassetti, portacravatte, portapantaloni, cassaforte, appendiabiti inclinabile, specchio. Finitura: F30  
Design Centro Ricerche MAMM  
PESO: 170 kg - m<sup>3</sup>: 1 - COLLI: 6

MEASURES: L 108 W 59 H 264  
DESCRIPTION: Wardrobe with 2 doors made of cherry wood with a fine checkerboard decoration. Inside: 2 adjustable shelves and 2 clothes rails. Accessories on request: chest of 3 drawers, tie rack, trouser rack, electronic safe, lifting hanging, rail mirror. Finishing: F30. Design by centro Ricerche MAMM  
WEIGHT: 170 kg - m<sup>3</sup>: 1 - PIECES: 6

ART. 0390  
ARMADIO XILO

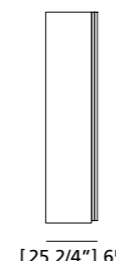
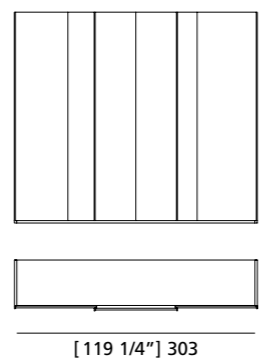

MISURE: L 303 P 65 H 263  
DESCRIZIONE: Armadio guardaroba con 3 ante scorrevoli, struttura in legno di ciliegio, ante impiallacciate con legno di ciliegio, padouk, noce, acero, ebano, frassino. All'interno 5 paletti appendiabiti.  
Finitura: F32  
Design: Centro Ricerche MAMM  
PESO: 330 kg - m<sup>3</sup>: 1,8 - COLLI: 9

MEASURES: L 303 P 65 H 263  
DESCRIPTION: Wardrobe with 3 sliding doors made of cherry, padouk, walnut, maple, ebony and ash wood. Inside 5 adjustable shelves with clothes rail. Finishing: F32  
Design: Centro Ricerche MAMM  
WEIGHT: 330 kg - m<sup>3</sup>: 1,8 - PIECES: 9

ART. 0371  
GUARDAROBA '900

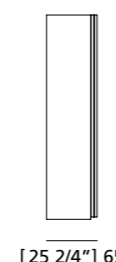
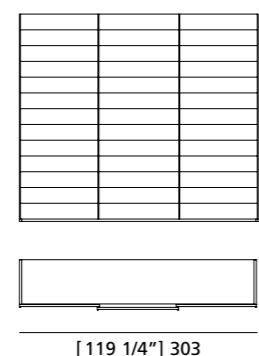

MISURE: L 303 P 65 H 263  
DESCRIZIONE: armadio guardaroba a 3 ante scorrevoli in legno di ciliegio con pregiata impiallacciatura a venature disallineate. Interno: 5 ripiani regolabili e 5 aste appendiabiti. Accessori su richiesta: cassetiera a 3 cassetti, portacravatte, portapantaloni, cassaforte, appendiabiti inclinabile, specchio. Finitura: F32/C  
Design Centro Ricerche MAMM  
PESO: 330 kg - m<sup>3</sup>: 1,8 - COLLI: 9

MEASURES: L 303 W 65 H 263  
DESCRIPTION: wardrobe with 3 sliding doors made of cherry wood with a fine grain misalignment. Inside: 5 adjustable shelves and 5 clothes rails. Accessories on request: chest of 3 drawers, tie rack, trouser rack, electronic safe, lifting hanging, rail mirror. Finishing: F32/C  
Design by centro Ricerche MAMM  
WEIGHT: 330 kg - m<sup>3</sup>: 1,8 - PIECES: 9

ART. 0372  
GUARDAROBA SCACCHI

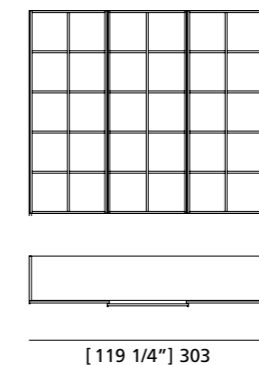

MISURE: L 303 P 65 H 263  
DESCRIZIONE: armadio guardaroba a 3 ante scorrevoli in legno di ciliegio con pregiata lavorazione a "scacchiera" e impiallacciatura a venature contrapposte. Interno: 5 ripiani regolabili e 5 aste appendiabiti. Accessori su richiesta: cassetiera a 3 cassetti, portacravatte, portapantaloni, cassaforte, appendiabiti inclinabile, specchio. Finitura: F32/C  
Design Centro Ricerche MAMM  
PESO: 330 kg - m<sup>3</sup>: 1,8 - COLLI: 9

MEASURES: L 303 W 65 H 263  
DESCRIPTION: wardrobe with 3 sliding doors made of cherry wood with a fine checkerboard decoration. Inside: 5 adjustable shelves and 5 clothes rails. Accessories on request: chest of 3 drawers, tie rack, trouser rack, electronic safe, lifting hanging, rail mirror. Finishing: F32/C  
Design by centro Ricerche MAMM  
WEIGHT: 330 kg - m<sup>3</sup>: 1,8 - PIECES: 9

ART. 0367  
ARMADIO RULMAN

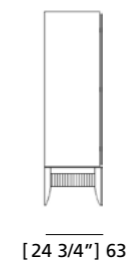
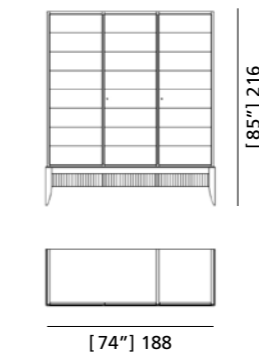

MISURE: L 188 P 63 H 216  
DESCRIZIONE: armadietto in legno di ciliegio a 3 ante con pregiata impiallacciatura a venature disallineate. Interno: 2 ripiani e 2 appendiabiti, 3 cassetti a scomparsa nel basamento con controfresatura a lesene. Finitura: F60  
Design Centro Ricerche MAMM  
PESO: 224 kg - m<sup>3</sup>: 1,5 - COLLI: 6

MEASURES: L 188 W 63 H 216  
DESCRIPTION: wardrobe made of cherry wood with 3 doors and 3 drawers. Doors veneered with a fine grain misalignment while drawers are decorated with a prestigious milling. Inside: 2 shelves and 2 clothes rails. Finishing: F60  
Design by centro Ricerche MAMM  
WEIGHT: 224 kg - m<sup>3</sup>: 1,5 - PIECES: 6

ART. 0302  
ARMADIO LUIGI FILIPPO

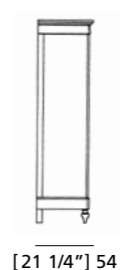
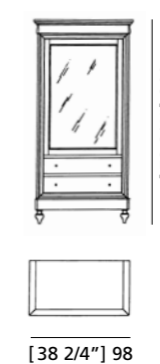

MISURE: L 98 P 54 H 200  
DESCRIZIONE: armadietto ad 1 porta a specchio con appendiabiti interno. 2 cassetti a vista ed 1 cassetto a scomparsa. Su richiesta porta a vetro o in legno.  
Finitura: F60  
Design Centro Ricerche MAMM  
PESO: 82 kg - m<sup>3</sup>: 1,2 - COLLI: 1

MEASURES: L 98 W 54 H 200  
DESCRIPTION: one-door cabinet with mirror, 2 drawers and 1 hidden small drawer. Inside clothing rail. Upon request wooden or glass door. Finishing: F60  
Design by centro Ricerche MAMM  
WEIGHT: 82 kg - m<sup>3</sup>: 1,2 - PIECES: 1

ART. 0303  
ARMADIO BIEDERMEIER

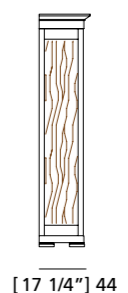
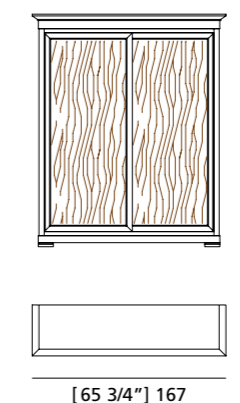

MISURE: L 167 P 44 H 200  
DESCRIZIONE: Armadio con struttura in legno di ciliegio, due ante scorrevoli, ripiani interni regolabili su scaletta in legno, due appendini interni.  
Finitura: F60  
Design: Centro Ricerche MAMM  
PESO: 130 kg - m<sup>3</sup>: 1,5 - COLLI: 2

MEASURES: L 167 P 44 H 200  
DESCRIPTION: Wardrobe with sliding doors and adjustable shelf inside with clothes rail. Made of cherry wood. Finishing: F60  
Design: Centro Ricerche MAMM  
WEIGHT: 130 kg - m<sup>3</sup>: 1,5 - PIECES: 2

ART. 0374  
GUARDAROPA DIRETTORIO

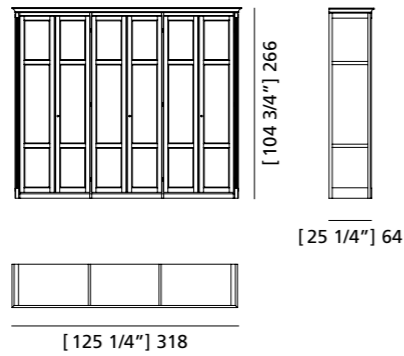

MISURE: L 318 P 64 H 266  
DESCRIZIONE: Armadio guardaroba a 6 ante in legno di ciliegio con pregiata fresatura sui fianchi e cornice di chiusura. Interno: 5 ripiani regolabili e 5 aste appendiabiti. Accessori su richiesta: cassetiera a 3 cassetti, portacravatte, portapantaloni, cassaforte, appendiabiti inclinabile, specchio. Finitura: F34 Design Centro Ricerche MAMM  
PESO: 300 kg - m<sup>3</sup>: 1,8 - COLLI: 10

MEASURES: L 318 W 64 H 266  
DESCRIPTION: Wardrobe with 6 doors made of cherry wood with a fine milling on the sides and decorating frame. Inside: 5 adjustable shelves and 5 clothes rails. Accessories on request: chest of 3 drawers, tie rack, trouser rack, electronic safe, lifting hanging, rail mirror. Finishing: F34 Design by centro Ricerche MAMM  
WEIGHT: 300 kg - m<sup>3</sup>: 1,8 - PIECES: 10

ART. 0378  
GUARDAROPA DIRETTORIO

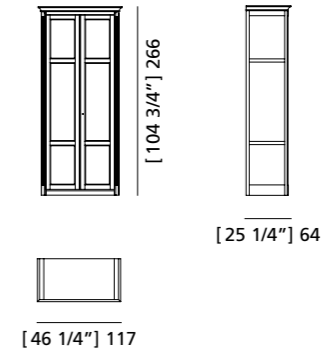

MISURE: L 117 P 64 H 266  
DESCRIZIONE: armadio guardaroba a 2 ante in legno di ciliegio con pregiata fresatura sui fianchi e cornice di chiusura. Interno: 2 ripiani regolabili e 2 aste appendiabiti. Accessori su richiesta: cassetiera a 3 cassetti, portacravatte, portapantaloni, cassaforte, appendiabiti inclinabile, specchio. Finitura: F34 Design Centro Ricerche MAMM  
PESO: 170 kg - m<sup>3</sup>: 1 - COLLI: 6

MEASURES: L 117 W 64 H 266  
DESCRIPTION: wardrobe with 2 doors made of cherry wood with a fine milling on the sides and decorating frame. Inside: 2 adjustable shelves and 2 clothes rails. Accessories on request: chest of 3 drawers, tie rack, trouser rack, electronic safe, lifting hanging, rail mirror. Finishing: F34 Design by centro Ricerche MAMM  
WEIGHT: 170 kg - m<sup>3</sup>: 1 - PIECES: 6

ART. 0375  
GUARDAROPA DIRETTORIO

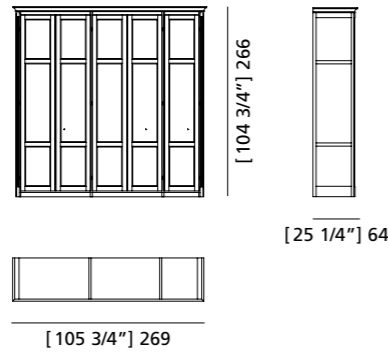

MISURE: L 269 P 64 H 266  
DESCRIZIONE: armadio guardaroba a 5 ante in legno di ciliegio con pregiata fresatura sui fianchi e cornice di chiusura. Interno: 5 ripiani regolabili e 5 aste appendiabiti. Accessori su richiesta: cassetiera a 3 cassetti, portacravatte, portapantaloni, cassaforte, appendiabiti inclinabile, specchio. Finitura: F34 Design Centro Ricerche MAMM  
PESO: 280 kg - m<sup>3</sup>: 1,7 - COLLI: 9

MEASURES: L 269 W 64 H 266  
DESCRIPTION: wardrobe with 5 doors made of cherry wood with a fine milling on the sides and decorating frame. Inside: 1 chest of 3 drawers, 5 adjustable shelves and 5 clothes rails. Accessories on request: tie rack, trouser rack, electronic safe, lifting hanging, rail mirror. Finishing: F34 Design by centro Ricerche MAMM  
WEIGHT: 280 kg - m<sup>3</sup>: 1,7 - PIECES: 9

ART. 0376  
GUARDAROPA DIRETTORIO

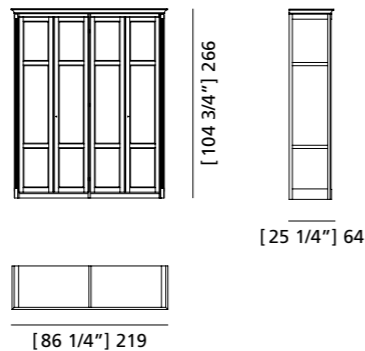

MISURE: L 219 P 64 H 266  
DESCRIZIONE: Armadio guardaroba a 4 ante in legno di ciliegio con pregiata fresatura sui fianchi e cornice di chiusura. Interno: 4 ripiani regolabili e 4 aste appendiabiti. Accessori su richiesta: cassetiera a 3 cassetti, portacravatte, portapantaloni, cassaforte, appendiabiti inclinabile, specchio. Finitura: F34 Design Centro Ricerche MAMM  
PESO: 255 kg - m<sup>3</sup>: 1,5 - COLLI: 8

MEASURES: L 219 W 64 H 266  
DESCRIPTION: wardrobe with 4 doors made of cherry wood with a fine milling on the sides and decorating frame. Inside: 4 adjustable shelves and 4 clothes rails. Accessories on request: chest of 3 drawers, tie rack, trouser rack, electronic safe, lifting hanging, rail mirror. Finishing: F34 Design by centro Ricerche MAMM  
WEIGHT: 255 kg - m<sup>3</sup>: 1,5 - PIECES: 8

ART. 0377  
GUARDAROPA DIRETTORIO

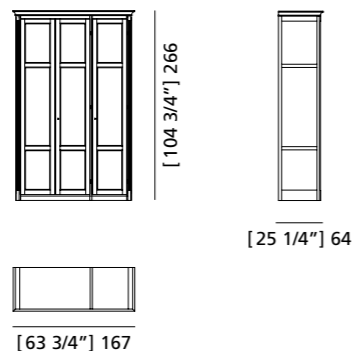

MISURE: L 167 P 64 H 266  
DESCRIZIONE: armadio guardaroba a 3 ante in legno di ciliegio con pregiata fresatura sui fianchi e cornice di chiusura. Interno: 4 ripiani regolabili e 4 aste appendiabiti. Accessori su richiesta: cassetiera a 3 cassetti, portacravatte, portapantaloni, cassaforte, appendiabiti inclinabile, specchio. Finitura: F34 Design Centro Ricerche MAMM  
PESO: 228 kg - m<sup>3</sup>: 1,2 - COLLI: 7

MEASURES: L 167 W 64 H 266  
DESCRIPTION: wardrobe with 3 doors made of cherry wood with a fine milling on the sides and decorating frame. Inside: 4 adjustable shelves and 4 clothes rails. Accessories on request: chest of 3 drawers, tie rack, trouser rack, electronic safe, lifting hanging, rail mirror. Finishing: F34 Design by centro Ricerche MAMM  
WEIGHT: 228 kg - m<sup>3</sup>: 1,2 - PIECES: 7

ART. A0101255  
PORTA PANTALONI

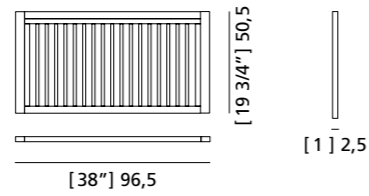

MISURE: L 96,5 P 50,5 H 2,5  
DESCRIZIONE: porta pantaloni  
PESO: 5 kg - m<sup>3</sup>: 0,03  
COLLI: 1

MEASURES: L 96,5 W 50,5 H 2,5  
DESCRIPTION: trouser rack.  
WEIGHT: 5 kg - m<sup>3</sup>: 0,03  
PIECES: 1

ART. A0101245  
PORTA CRAVATTE

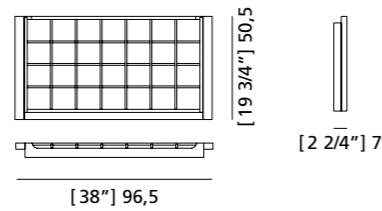

MISURE: L 96,5 P 50,5 H 7  
DESCRIZIONE: porta cravatta  
PESO: 4 kg - m<sup>3</sup>: 0,01  
COLLI: 1

MEASURES: L 96,5 W 50,5 H 7  
DESCRIPTION: tie rack.  
WEIGHT: 4 kg - m<sup>3</sup>: 0,01  
PIECES: 1

ART. S1000015  
CASSETTIERA INTERNA

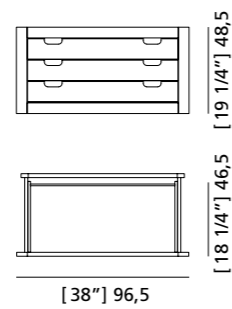

MISURE: L 96,5 P 46,5 H 48,5  
DESCRIZIONE: cassettera interna  
PESO: 20 kg - m<sup>3</sup>: 0,30  
COLLI: 1

MEASURES: L 96,5 W 46,5 H 48,5  
DESCRIPTION: internal chest of drawers.  
WEIGHT: 20 kg - m<sup>3</sup>: 0,30  
PIECES: 1

ART. S0900055  
RIPIANO INTERNO

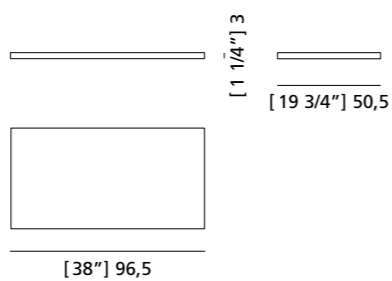

MISURE: L 96,5 P 50,5 H 3  
DESCRIZIONE: ripiano interno  
PESO: 2 kg - m<sup>3</sup>: 0,01  
COLLI: 1

MEASURES: L 96,5 W 50,5 H 3  
DESCRIPTION: internal shelf.  
WEIGHT: 2 kg - m<sup>3</sup>: 0,01  
PIECES: 2



FINITURE  
TESSUTI

FINISH  
FABRICS

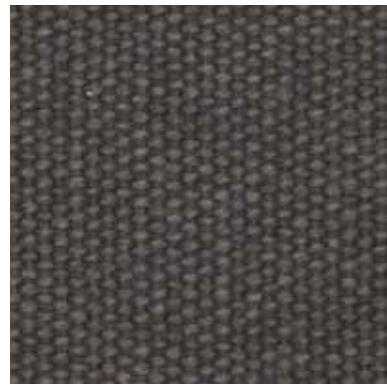

ART. A112031S

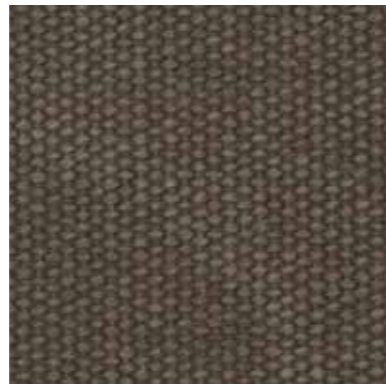

ART. A112032S



ART. A112059S



ART. A112045S

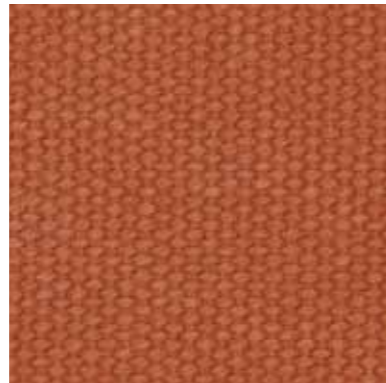

ART. A112046S



ART. A112064S

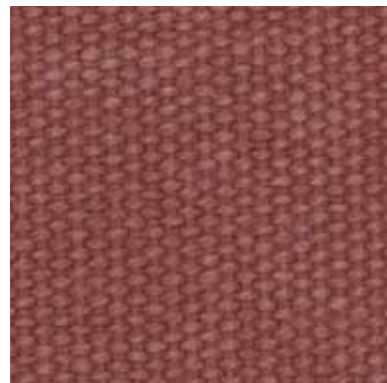

ART. A112047S



ART. A112048S



ART. A112062S



ART. A112035S

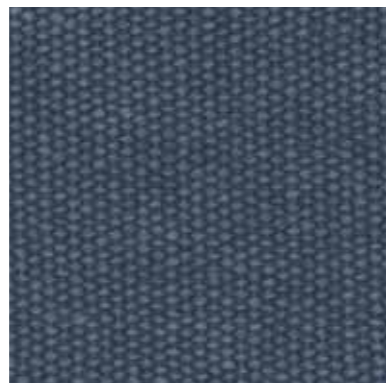

ART. A112036S

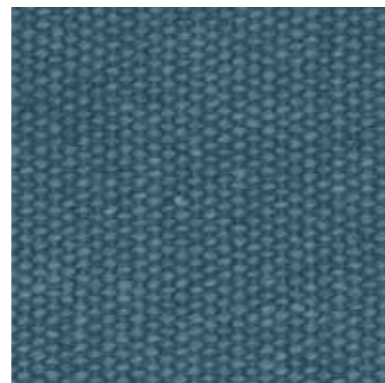

ART. A112037S

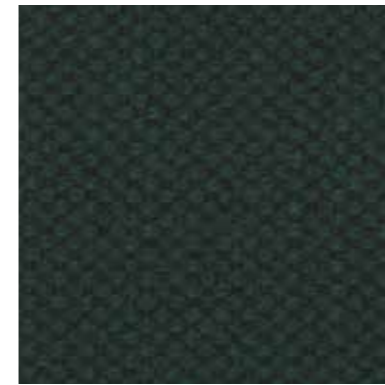

ART. A112065S

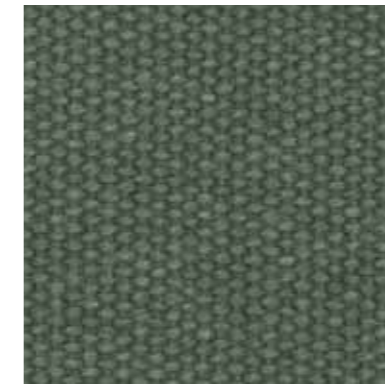

ART. A112043S

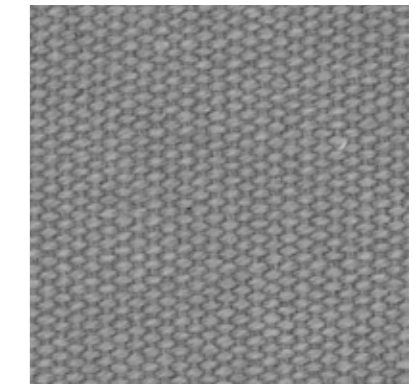

ART. A112051S

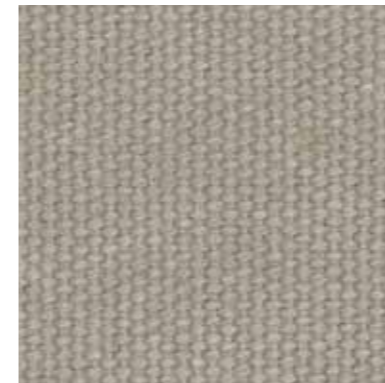

ART. A112052S

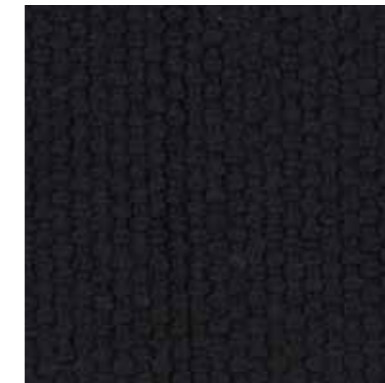

ART. A112066S



ART. A112030S

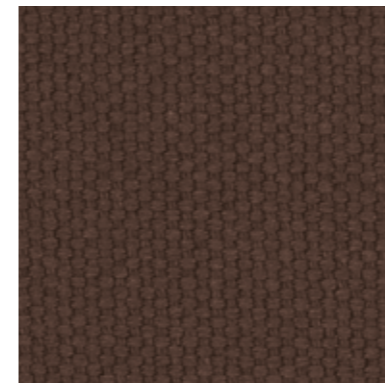

ART. A112060S



ART. A112034S



ART. A112033S

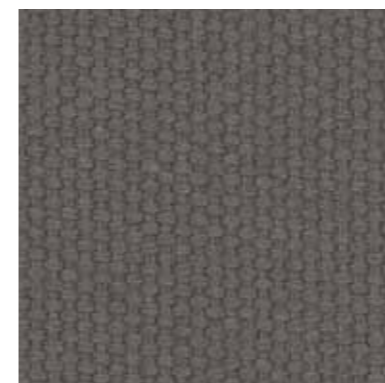

ART. A112049S

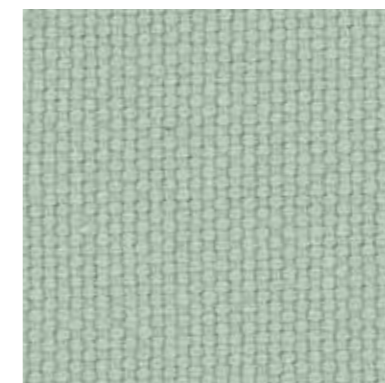

ART. A112061S



ART. A112063S



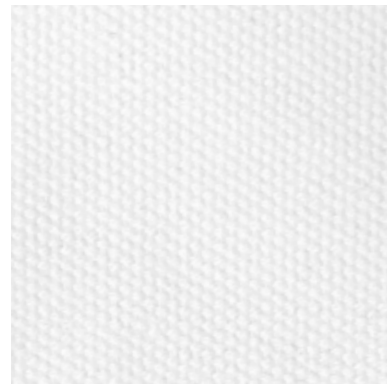

ART. A112058S



ART. A112040S



ART. A112042S



ART. A112056S



ART. A112057S



ART. A112055S



ART. A112050S



ART. A112054S



ART. A112044S



ART. A112041S



ART. A112039S



ART. A112038S



ART. A113236S BLANC



ART. A113235S NATUREL



ART. A113238S ROSE



ART. A113237S JAUNE TENDRE

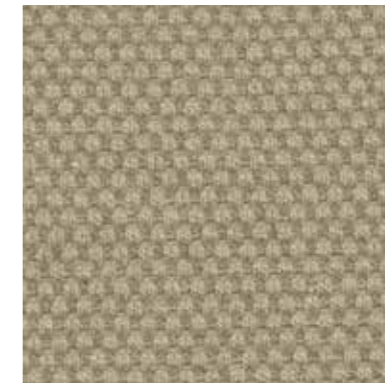

ART. A113234S GRIS CLAIRE



ART. A113240S MASTIC

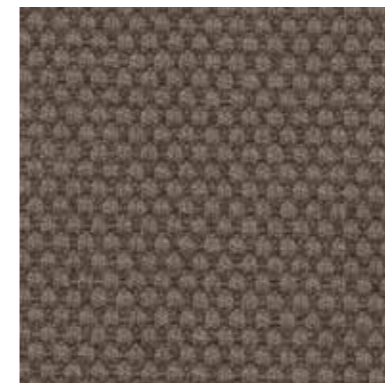

ART. A113242S BOUE



ART. A113239S ARGILE



ART. A113244S MARRON GLACE



ART. A113241S SOURIS



ART. A113245S BLEU DE PRUSSE



ART. A113243S ACIER



ART. A113224S BLANC



ART. A113225S JAUNE TENDRE



ART. A113223S NATUREL



ART. A113226S ROSE



ART. A113222S GRIS CLAIRE



ART. A113229S SOURIS



ART. A113228S MASTIC



ART. A113227S ARGILE



ART. A113230S BOUE



ART. A113231S ACIER



ART. A113233S BLEU DE PRUSSE



ART. A113232S MARRON GLACE



ART. A113211S MADREPERLA



ART. A113219S ROSE



ART. A113217S SUNSET



ART. A113220S VIOLET



ART. A113218S DIASPRO



ART. A113221S SMOKE



ART. A113210S ARGENT



ART. A113212S ARTIC



ART. A113215S DENIM



ART. A113214S OLTREMARE



ART. A113213S FIORDO



ART. A113216S FOREST



ART. A115001S



ART. A115002S



ART. A115004S



ART. A115003S

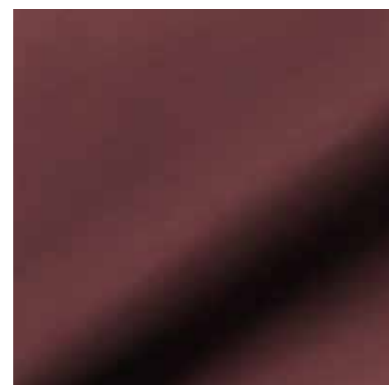

ART. A115011S

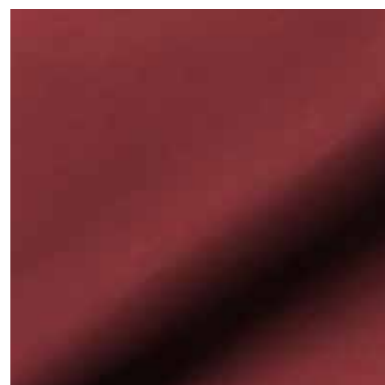

ART. A115012S



ART. A115009S



ART. A115007S



ART. A115008S



ART. A115005S

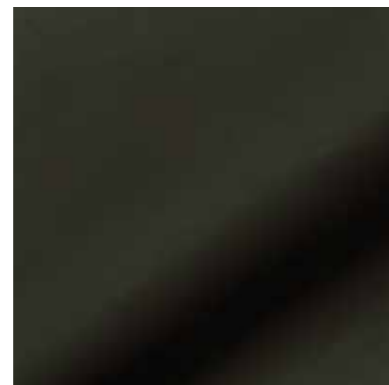

ART. A115006S

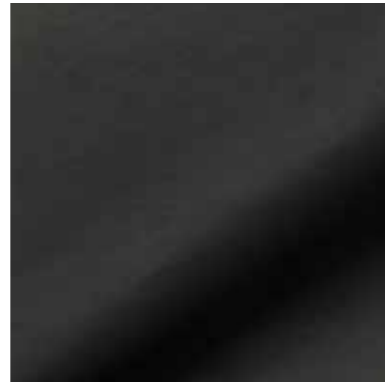

ART. A115010S

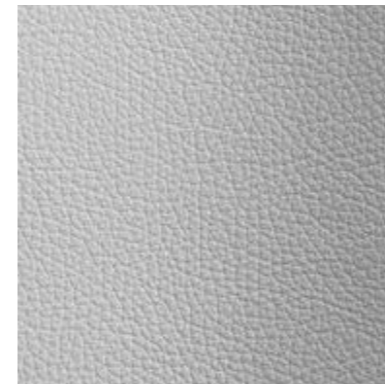

ART. A114039S



ART. A114031S



ART. A114032S

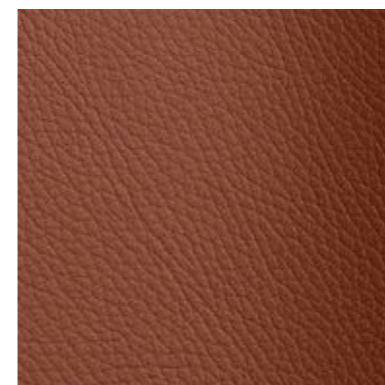

ART. A114053S

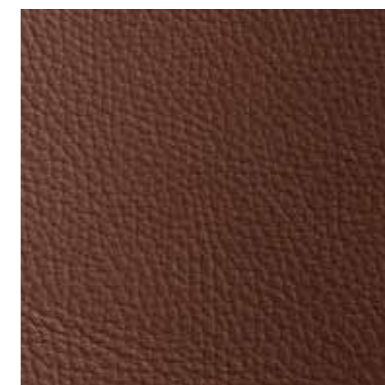

ART. A114036S



ART. A114035S



ART. A114040S



ART. A114037S



ART. A114030S

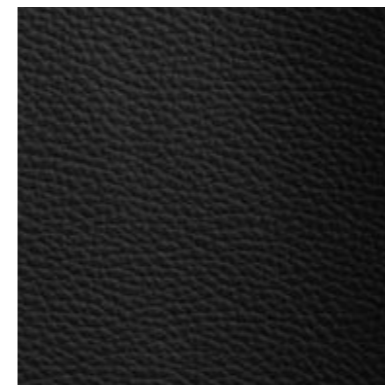

ART. A114038S



ART. A114034S



ART. A1140052S



ART. A114015S



ART. A114017S



ART. A114016S



ART. A114055S



ART. A114054S



ART. A114018S



ART. A114019S



ART. A114044S



ART. A114056S



ART. A114026S



ART. A114059S



ART. A114025S



ART. A114014S



ART. A114027S



ART. A114051S



ART. A114024S



ART. A114023S

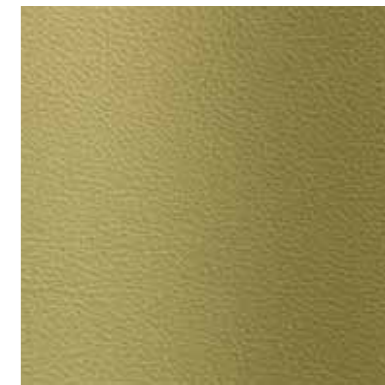

ART. A114022S



ART. A114021S



ART. A114020S



ART. A114057S



ART. A114047S



ART. A114028S



ART. A114029S



ART. A1140585



ART. A1140105



ART. A1140115

I mobili della produzione Morelato sono realizzati usando legno di:  
Acerò, Ciliegio, Ebano, Frassino, Noce Canaletto, Padouk, Wengè, Zebrano, Rovere.  
Le essenze sono poi trattate con diverse possibilità di finitura superficiale.

*The Morelato furniture is made using the following wood:  
Maple, Cherry, Ebony, Walnut, Padouk, Wengè, Zebrano and Oak.  
The surfaces of the wood are then treated with different kinds of finishing.*



ACERO

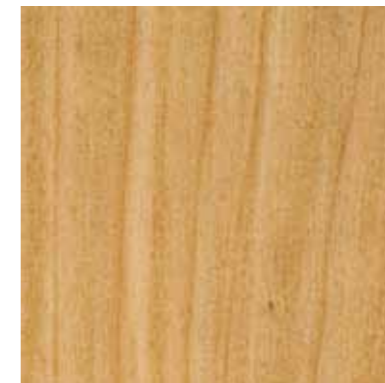

CILIEGIO



EBANO



FRASSINO



NOCE CANALETTO



PADOUK



WENGÉ



ROVERE



ZEBRANO

FINITURE PER MOBILI IN ESSENZA DI CILIEGIO  
FINISHING FOR CHERRY WOOD FURNITURE



F32/C TRASPARENTE



F30 FINITURA NATURALE



F34 FINITURA ACERO



F60 FINITURA CILIEGIO



F80 FINITURA MOGANO



F100 FINITURA NOCE

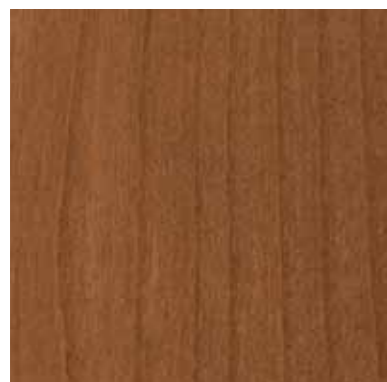

F160 FINITURA NOCE CANALETTO

FINITURE PER MOBILI IN ESSENZA DI FRASSINO  
FINISHING FOR ASH WOOD FURNITURE



F32/F TRASPARENTE



F140 FINITURA COLORE NERO



F150 FINITURA COLORE WENGÉ



F160 FINITURA COLORE NOCE



F170 FINITURA COLORE ROVERE



F180 FINITURA COLORE MOKA

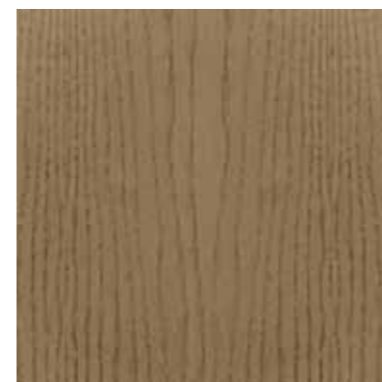

F190 FINITURA COLORE CASTAGNO

---

FINITURE PER MOBILI IN ESSENZA  
DI ACERO  
FINISHING FOR MAPLE WOOD  
FURNITURE

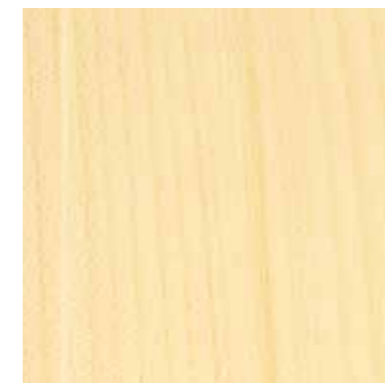

F32/A  
TRASPARENTE

FINITURE PER MOBILI IN ESSENZA  
DI NOCE CANALETTO  
FINISHING FOR WALNUT WOOD  
FURNITURE



F32/N  
TRASPARENTE



F.L.1 FINITURA LACCATO  
BORDATO VERDE



F.L.2 FINITURA LACCATO  
BORDATO AZZURRO



F.L.5 FINITURA LACCATO  
BORDATO MARRONE



F.L.50 FINITURA COLORATO  
NERO OPACO



F.L.60 FINITURA COLORATO  
BIANCO OPACO



F.L.80 FINITURA COLORATO  
VERDE



F.L.11 FINITURA COLORATO  
BEIGE



F.L.90 FINITURA COLORATO  
ARANCIO



F.L.100 FINITURA COLORATO  
AZZURRO



F.L. 120 FINITURA COLORATO  
GRIGIO



F.L. 130 FINITURA COLORATO  
GIALLO



F.L.140 FINITURA COLORATO  
ROSSO



F.L.150 FINITURA COLORATO  
BLUE



F.L. 20 FOGLIA ORO



F.L. 21 FOGLIA ARGENTO



F.L. 160 FINITURA COLORATO  
TORTORA



F.L.170 FINITURA COLORATO  
SABBIA

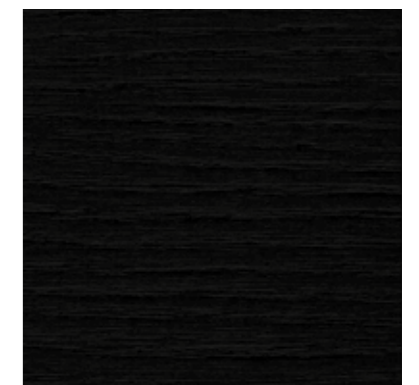

F.L.180 FINITURA COLORATO  
ANTRACITE